

ABOUT US

关于我们

东莞市江龙智能科技有限公司，是一家专业从事工业厚料缝纫机研发、生产、销售为一体的企业；江龙公司起源于2005年，地处于中国制造业名城——东莞，19年缝纫设备产业发展经验，是一家以“**聚焦、专注、简单、感恩**”为核心价值观制造生产型企业。

公司拥有专业研发团队，标准的生产流水线，经验丰富的工程师，完善的管理理念和人性化的管理制度。还拥有多款专利产品，生产的工业缝纫机适用于箱包、手袋、皮具、足球、汽车椅套、脚垫、沙发、鞋帽等厚料的缝制。产品符合国际标准，除了在全国销售之外，还出口到东南亚、欧洲等世界各地。

公司以“**质量求生存，信誉求发展**”为经营理念，以精密的零件、精湛的技术、先进的设备为前提，以高素质的人才为依托，以诚信一流的售后服务为保障，赢得了客户的信赖，得到了国内外客户的一致好评。创新、拼搏、责任、诚信！对尖端技术的追求、对卓越品质的执着成就了江龙公司在缝制设备发展史上的不朽功勋！江龙公司正以全新的面貌、昂扬的姿态迈向国际缝制机械产业的前沿，“博观而约取，厚积而薄发”，从中国制造到中国创造，江龙公司将在国际缝制设备行业中脱颖而出，让“中国智造”引领世界潮流！

东莞市江龙智能科技有限公司 Dongguan Jianglong Intelligent Technology Co., Ltd

Dongguan Jianglong Intelligent Technology Co., Ltd. was established in 2005 and is located in Dongguan City, Guangdong Province. It is an enterprise integrating R&D, manufacturing and sales. We have 19 years of experience in the development of the industrial sewing machines and are a manufacturing enterprise with the core values of "Focus, Concentration, Simplicity, and Gratitude".

Jianglong company has a professional R&D team, standard production lines, experienced engineers, sound management concepts and humanized management system. Our industrial sewing machines are suitable for sewing ABS plastic suitcases, handbags, car mats/seats, saddles, canvas or leather goods, shoes and other thick materials. We also have a number of patented sewing machines that meet international standards and are exported to the USA, the UK, the Netherlands, Australia, Turkey, Saudi Arabia and other countries around the world.

Jianglong company takes "Survive Based on Quality, Develop Based on Reputation" as business philosophy, takes precision parts, superb technology and advanced equipment as the premise, relies on high-quality professionals, and guarantees first-class after-sales service, and has won the unanimous praise from customers at home and abroad. "Innovation, Hardwork, Responsibility and Integrity"! The pursuit of high technology and the persistence of excellent quality have made our company achievements in the history of sewing equipment development! Jianglong company is moving towards the forefront of the international sewing machinery industry with a new look and a high-spirited attitude. From MADE IN CHINA to CREATED IN CHINA, Jianglong sewing machines will stand out in the international sewing equipment industry and let "INTELLIGENT MADE IN CHINA" lead the world trend!

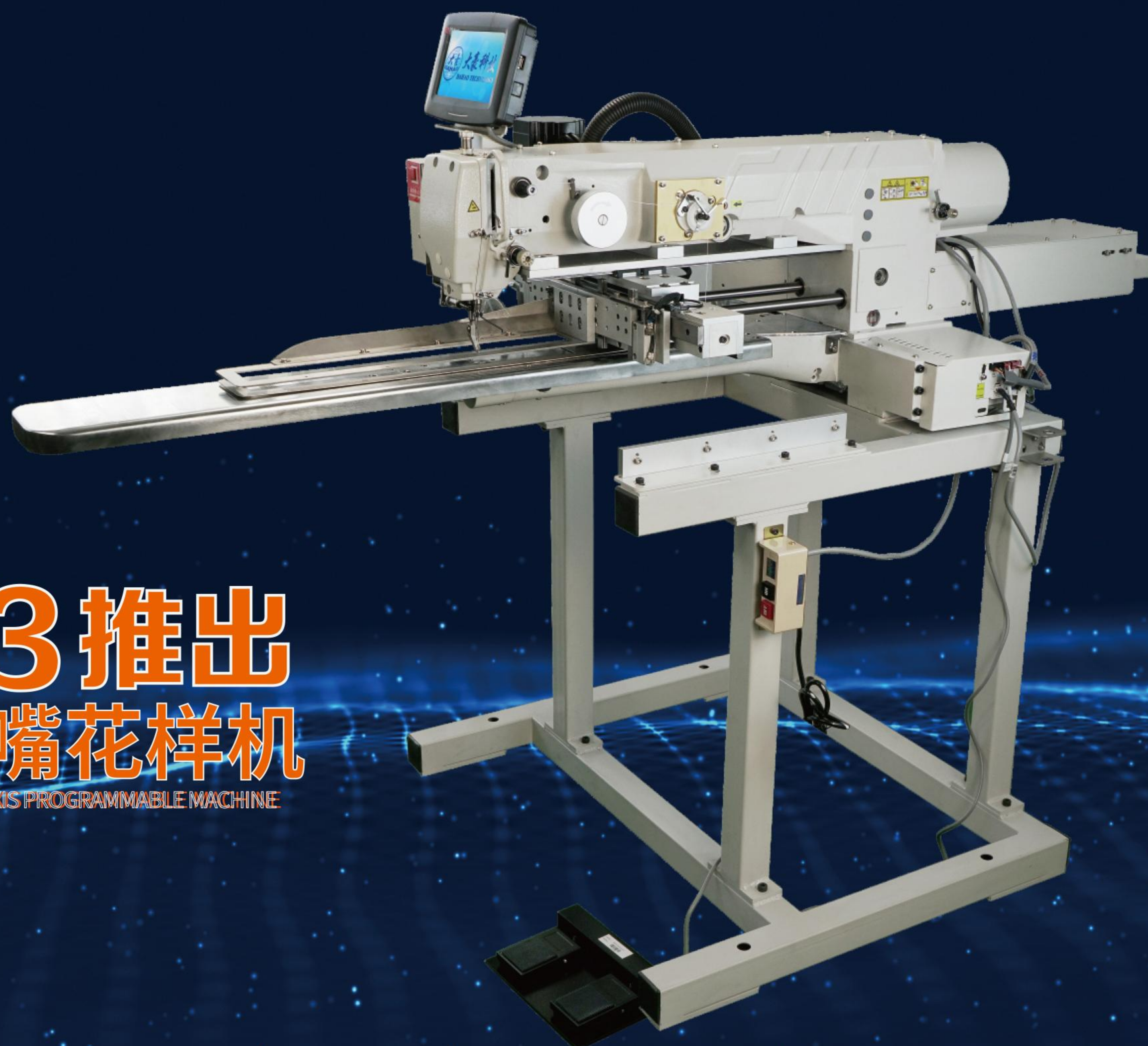

2023 推出 4040小嘴花样机

THE FIRST INTERNAL TWIN-AXIS PROGRAMMABLE MACHINE

发展历程 development history

2023年

厚料曲折缝家用机下线，同时研发推出电脑直驱款厚料曲折缝家用机专利产品特长小嘴4040电脑花样机成功上市，推出自动打版3520K/3525K电脑花样机，深受市场追捧，推出专利产品：电动热切机。
-Launched the patented product over-length small diameter JL-4040 computer pattern machine.
-Launched auto programming JL3520K/JL-3525K computer pattern machine, which were well received by the market.
-Launched a zigzag household sewing machine for thick materials, and developed and launched a direct-drive computer version zigzag household sewing machine.
-Launched a new patented product: Electric drive edge tape hot heat cutting machine.

2021年

推出4030、5030、6040大范围花样机，满足多样性市场需求。研发并生产出专利产品：气动热切机，上市后迅速赢得市场认可，广泛获得客户推崇。Launched JL-4030, JL-5030, JL-6040 large-scale computerized programmable electronic pattern machine to meet the needs of diverse markets. Developed and produced a patented product Pneumatic Drive Edge Tape Hot Heat Cutting Machine, which quickly won market recognition after launch.

2019年

推出电脑花样机 3020/3520系列机型，推出国内首台框架式连体内双轴花样机。Launched the computerized pattern machine JL-3020/JL-3520 series, which is the first frame-connected internal twin-axis programmable electronic pattern sewing machine in China.

2017年

推出国内首台直驱电脑小嘴高车246-2AD；并隆重推向市场

Launched the first direct-drive 50mm diameter cylinder arm sewing machine JL-246-2AD in china.

8月荣获高新技术企业培育入库。
In August, our company was awarded the title of High-Tech Enterprise.

9月研发新品6860DT自动剪线高车，成功上市。
In September, launched the new arrival auto trimming cylinder arm sewing machine JL-6860DT.

2015年

推出国内首台直驱电脑大嘴高车8B-2AD
Launched the first direct-drive 70mm diameter cylinder arm sewing machine JL-8B-2AD in china.

2013年

推出0303D电脑同步车系列机型，满足客户针对性需求
Launched the 0303D computerized top and bottom feed lockstitch sewing machine in series models to meet the targeted needs of customers.

2011年

推出国内第一台全自动润油型11mm特大针距高车JL-1341，并赢得汽车脚垫及PVC拉杆箱领域得到客户青睐
Launched the first fully automatic oil supply JL-1341 cylinder arm sewing machine in China(max stitching length 11mm), which has been loved by customers in the field of car mats and PVC plastic suitcases.

2009年

金融危机期间，凭借优质的产品及超值的性价比，公司生产的8B/246机型市场占有率份额引领同行，良好的合作信誉得到众供应商的认可。
During the financial crisis, with high-quality machines and excellent value for money, the market share of the JL-8B/JL-246 models produced by our factory led the peers, and our good reputation for cooperation was recognized by a lot of customers.

2007年

东莞江龙针车设备成立
Dongguan Jianglong Sewing Machine Equipment Co., Ltd. was established.

2005年

始创于深圳，入行缝制设备研发生产
Founded in Shenzhen, engaged in R&D and production of sewing equipment.

2022年

获评行业“专精特新”称号，改良升级8B、246、341多款机型为直驱电脑机型，引领加速缝纫机升级，迭代。

Awarded the title of "Specialized And Sophisticated Enterprises That Produce New And Unique Products" in the sewing machine industry, many models of 8B, 246, and 341 have been improved to direct-drive computer models, leading and accelerating the upgrade of industrial sewing machines.

2020年

疫情期间抗疫物资紧缺，响应国家号召研发并生产出口罩耳绳点焊机，封边机。During the COVID-19, the pandemic supplies are very scarce, our factory responds positively to the national call to develop and produces spot welding machine and sealing machine for medical mask strap.

2018年

推出自动剪线、三同步车DU 5500单针，5520双针系列厚料车缝机和8BL大梭高车,推出国内首台自动剪线8BDT高车，深受市场欢迎

Launched automatic thread trimming, compound feed walking foot DU JL-5500 single needle, JL-5520 double needle series thick material sewing machine and JL-8BL big shuttle hook cylinder arm sewing machine. Launched the first automatic thread trimming JL-8BDT cylinder arm sewing machine in China, which was well received by the market.

2016年

成立外贸部门，国际站，诚信通等电子商务部门，集合互联网与线下终端客户拉近距离更好的服务

Set up a foreign trade department, open a number of e-commerce platforms, close the distance with customers through the Internet, and better serve customers.

2014年

成立：“东莞市寮步江龙针车有限公司”；成为深圳缝纫机协会“会员单位”
Established DONGGUAN LIAOBU JIANGLONG SEWING MACHINE CO., LTD. Become one of the MEMBER UNITS of Shenzhen Sewing Machine Association.

2012年

成立特种机研发制造车间，满足特殊订制需求

Established a special machine R&D and manufacturing workshop to meet the demand for special customization.

2010年

缝制设备行业火爆的一年，在众多供应商鼎力支持下，公司生产销售大幅度提升，同时奠定了江龙牌针车在市场行业坚实基础
Was a hot year for the sewing equipment industry. With the strong support of many customers, our company's production and sales increased significantly, which has laid a solid foundation for Jianglong factory in the industry.

2008年

推出国内第一台全自动润油型小嘴高车246-2A，迅速得到市场认可
Launched the first automatic oil supply JL-246-2A small cylinder arm sewing machine in China, which quickly gained market recognition.

2006年

首批厚料缝制机型下线，凭借优良的服务，过硬的品质深得广大客户同行认可
The first batch of industrial sewing machines was produced. Jianglong Factory has won the recognition of customers and peers for our excellent service and superb quality.

CONTENTS 目录

电脑花样机系列 Programmable Electronic Pattern Sewing Machine Series

- 01 **R3520K/R3525K**
直驱连体内双轴电脑花样机
Direct Drive Integrated Dual Axis Programmable Electronic Pattern Sewing Machine
- 02 **RG3520/G3525/3520/3525**
直驱连体内双轴电脑花样机
Direct Drive Integrated Dual Axis Programmable Electronic Pattern Sewing Machine
- 03 **RG5030K/R5030K**
直驱连体内双轴电脑花样机
Direct Drive Integrated Dual Axis Programmable Electronic Pattern Sewing Machine
- 04 **RG6040K/R6040K**
直驱式大范围电脑花样机
Direct Drive Large Area Programmable Electronic Pattern Sewing Machine
- 05 **RX4040/RX3040**
直驱式小嘴电脑花样机
Direct Drive Small Cylinder Bed Programmable Electronic Pattern Sewing Machine
- 06 **R430D**
电脑直驱式平缝打结机
Direct Drive Bar Tacking Lockstitch Sewing Machine(Sewing Area: 40*30mm)
- RG3520K/RG3525K**
直驱连体内双轴电脑花样机
Direct Drive Integrated Dual Axis Programmable Electronic Pattern Sewing Machine
- R3020T/R3520T/R3525T**
直驱连体内双轴电脑花样机
Direct Drive Integrated Dual Axis Programmable Electronic Pattern Sewing Machine
- RG4030/R4030**
直驱连体内双轴电脑花样机
Direct Drive Integrated Dual Axis Programmable Electronic Pattern Sewing Machine
- RG6040/R6040**
直驱式大范围电脑花样机
Direct Drive Large Area Programmable Electronic Pattern Sewing Machine
- R311G/R326G**
直驱电脑花样机
Direct Drive Programmable Electronic Pattern Sewing Machine
- R0906**
小型花样机
Direct Drive Lockstitch Pattern Tacking Sewing Machine(Sewing Area: 90*60mm)

小嘴高车系列 Cylinder Bed Sewing Machine Series (Cylinder Diameter: 47.5mm & 50mm)

- 07 **R246-C/R246D1-C**
加长型筒式综合送料小嘴高车
Long Arm Cylinder Bed Walking Foot Lockstitch Sewing Machine (Cylinder Diameter: 50mm)
- 08 **R246D1-2AD**
筒式综合送料直驱电脑小嘴高车
Direct Drive Cylinder Bed Walking Foot Lockstitch Sewing Machine (Cylinder Diameter: 50mm)
- 09 **R246-2/246-2A**
筒式综合送料小嘴高车
Cylinder Bed Walking Foot Lockstitch Sewing Machine (Cylinder Diameter: 50mm)
- 10 **R246-/246-A**
筒式综合送料小嘴高车
Cylinder Bed Walking Foot Lockstitch Sewing Machine (Cylinder Diameter: 50mm).
- 11 **R244D1-2AD**
筒式综合送料直驱电脑小嘴高车
Direct Drive Cylinder Bed Walking Foot Lockstitch Sewing Machine (Cylinder Diameter: 47.5mm)
- 12 **R244/244-A**
筒式综合送料小嘴高车
Cylinder Bed Walking Foot Lockstitch Sewing Machine (Cylinder Diameter: 47.5mm)
- R246D-2A/R246VD3-2A**
筒式综合送料直驱电脑小嘴高车
Direct Drive Cylinder Bed Walking Foot Lockstitch Sewing Machine (Cylinder Diameter: 50mm)
- R246D3-2/R246V-2**
筒式综合送料&同步式水平送料小嘴高车
Cylinder Bed Walking Foot Lockstitch Sewing Machine (Cylinder Diameter: 50mm).
- R244D3/244V**
筒式综合送料&同步式水平送料小嘴高车
Cylinder Bed Walking Foot Lockstitch Sewing Machine (Cylinder Diameter: 50mm)
- R244D3-2/244V-2**
筒式综合送料&同步式水平送料小嘴高车
Direct Drive Cylinder Bed Walking Foot Lockstitch Sewing Machine (Cylinder Diameter: 47.5mm)
- R244D3/244V**
筒式综合&同步式水平送料小嘴高车
Cylinder Bed Walking Foot Lockstitch Sewing Machine (Cylinder Diameter: 47.5mm)

大嘴高车系列 Cylinder Bed Sewing Machine Series (Cylinder Diameter: 70mm)

- 13 **R6860DT**
筒式综合送料自动剪线高车
Cylinder Bed Walking Foot Lockstitch Sewing Machine (Cylinder Diameter: 70mm)
- R6860D1-Q/R6860VD1**
筒式综合&水平送料直驱电脑高车
Direct Drive Cylinder Bed Walking Foot Lockstitch Sewing Machine (Cylinder Diameter: 70mm).
- 14 **R1341/R1341L**
筒式综合送料大嘴高车
Cylinder Bed Walking Foot Lockstitch Sewing Machine (Cylinder Diameter: 70mm)
- R21341L/R26860L-D1**
筒式双针综合送料高头车
Two Needle Cylinder Bed Walking Foot Lockstitch Sewing Machine (Cylinder Diameter: 70mm).
- 15 **R341**
筒式综合送料大嘴高车
Cylinder Bed Walking Foot Lockstitch Sewing Machine (Cylinder Diameter: 70mm)
- R341D3-2/341D2-2**
筒式综合送料大嘴高车
Cylinder Bed Walking Foot Lockstitch Sewing Machine (Cylinder Diameter: 70mm)
- 16 **R1341-C/1341D3-C**
加长型筒式综合送料高车
Long Arm Cylinder Bed Walking Foot Lockstitch Sewing Machine (Cylinder Diameter: 70mm)

中嘴高车系列 Cylinder Bed Sewing Machine Series (Cylinder Diameter: 65mm)

- 17 **R8BD-C/8B-C**
加长型筒式综合送料高车
Long Arm Cylinder Bed Walking Foot Lockstitch Sewing Machine (Cylinder Diameter: 65mm)
- R28BLD1-2A/R28B**
筒式双针综合送料高车
Two Needle Cylinder Bed Walking Foot Lockstitch Sewing Machine (Cylinder Diameter: 65mm)
- 18 **R8BDT**
筒式综合送料自动剪线高车
Cylinder Bed Auto Thread Trimming Walking Foot Lockstitch Machine (Cylinder Diameter: 65mm)
- R8BLD1-2A/38BD-2**
筒式综合送料直驱电脑高车
Direct Drive Cylinder Bed Walking Foot Lockstitch Sewing Machine (Cylinder Diameter: 65mm)
- 19 **R8B-2/8B-2A**
筒式综合送料高车
Cylinder Bed Walking Foot Lockstitch Sewing Machine (Cylinder Diameter: 65mm)
- R8B-2/8BLD3-2**
筒式综合送料单直驱高车
Cylinder Bed Walking Foot Lockstitch Sewing Machine (Cylinder Diameter: 65mm)
- 20 **R8B/8B-A**
筒式综合送料标准旋梭高车
Cylinder Bed Walking Foot Lockstitch Sewing Machine (Standard bobbin diameter 22mm)
- R8BLD3/8BLD3-A**
筒式综合送料大梭单直驱电脑高车
Direct Drive Cylinder Bed Walking Foot Lockstitch Sewing Machine (Bobbin Diameter: 22mm)

柱车系列 Post Bed Sewing Machine Series

- 21 **R8918**
竖筒型综合送料高柱车
Post Bed Walking Foot Lockstitch Sewing Machine
- R8918-15/R91818**
竖筒型综合送料高柱车
Post Bed Walking Foot Lockstitch Sewing Machine
- 22 **R8365**
竖筒型综合送料高柱车
Post Bed Walking Foot Lockstitch Sewing Machine
- R8365S/8365D3-A**
竖筒型综合送料高柱车
Post Bed Walking Foot Lockstitch Sewing Machine
- 23 **R8365R(360°)**
360度水平旋转柱车
360 Degree Horizontal Rotary Post Bed Walking Foot Lockstitch Sewing Machine
- R1341S(180°)**
180度前后摆臂车
180 Degree Rotary Post Bed Walking Foot Lockstitch Sewing Machine

三同步综合送料系列 Flat Bed Compound Feed Walking Foot Lockstitch Sewing Machine Series

- 24 **R5500DT/5520DT**
单双针自动剪线综合送料平缝机
One/Two Needle Automatic Thread Trimming Walking Foot Lockstitch Sewing Machine
- R4400D3/4420**
单双针综合送料平缝机
One/Two Needle Compound Feed Walking Foot Lockstitch Sewing Machine
- 25 **R6600-25/6620-25**
单双针综合送料平缝机
One/Two Needle Compound Feed Walking Foot Lockstitch Sewing Machine
- R4420H-7**
竖长型双针综合送料矮柱车
Post Bed Two Needle Compound Feed Walking Foot Lockstitch Sewing Machine
- 26 **R6600-40/6620-40**
加长型单双针综合送料平缝机
Long Arm One/Two Needle Compound Feed Walking Foot Lockstitch Sewing Machine

粗线车系列 Cylinder Bed Super Thick Lockstitch Sewing Machine Series

- 26 **R243**
综合送料摆梭粗线平缝机
Flat Bed Compound Feed Walking Foot Lockstitch Sewing Machine
- 27 **R441**
筒式摆梭综合送料粗线车
Cylinder Bed Compound Feed Walking Foot Lockstitch Sewing Machine
- R441F-37/441HX-24**
单针综合送料摆梭平缝机
Single Needle Cylinder Bed Compound Feed Walking Foot Lockstitch Thick Thread Sewing Machine

双针平缝机系列 Two Needle Flat Bed Compound Feed Lockstitch Sewing Machine Series

- 28 **R842DT/R8720DT**
双针针送自动剪线平缝机
Flat Bed Automatic Thread Trimming Compound Feed Walking Foot Lockstitch Sewing Machine
- R842/872D3**
双针针送平缝机
Two Needles Flat Bed Compound Feed Walking Foot Lockstitch Sewing Machine

筒式小嘴包边车系列 Cylinder Bed Small Diameter Binding Lockstitch Sewing Machine Series

- 29 **R335PF**
筒式水平送料小嘴包边车
Cylinder Bed Compound Feed Walking Foot Lockstitch Sewing Machine (Cylinder Diameter 46mm)
- R335PF/2628D**
筒式水平送料小嘴包边车
Cylinder Bed Compound Feed Walking Foot Lockstitch Sewing Machine (Cylinder Diameter 46mm)

同步车平车系列 Direct Drive Compound Feed Auto-trimming Lockstitch Sewing Machine Series

- 30 **R0303D**
自动剪线电脑同步车
Direct Drive Compound Feed Automatic Thread Trimming Walking Foot Lockstitch Sewing Machine
- R0303D2/0303D1-Q**
自动剪线电脑同步车
Direct Drive Compound Feed Automatic Thread Trimming Walking Foot Lockstitch Sewing Machine
- 31 **R0303DH**
自动剪线电脑同步车
Direct Drive Compound Feed Automatic Thread Trimming Walking Foot Lockstitch Sewing Machine
- R0303DH-RD/0306D2-Q**
自动剪线&小嘴电脑同步车
Direct Drive Automatic Thread Trimming & Small Cylinder Bed Lockstitch Sewing Machine
- 32 **R0303DX-Q**
自动剪线电脑同步车
Direct Drive Automatic Thread Trimming & Triple Bobbin Walking Foot Lockstitch Sewing Machine
- R8700D/R8900D**
自动剪线大梭&小梭电脑平车
Flat Bed Direct Drive Automatic Thread Trimming Lockstitch Sewing Machine

热切机系列 Edge Tape Hot Heat Cutting Machine Series

- 33 **RD01**
纯电动款包边热切机
Electric Drive Edge Tape Hot Heat Cutting Machine
- 34 **RQ301**
气动款包边热切机
Pneumatic Drive Edge Tape Hot Heat Cutting Machine

R3520K/R3525K

直驱连体内双轴电脑花样机

Direct Drive Integrated Dual Axis Programmable Electronic Pattern Sewing Machine

产品介绍

PRODUCT INTRODUCTION

- 专利外观, 美观独特。
- Y皮带挂钩座与机壳一体设计, 高精度。
- 采用高品质电磁阀、皮带、气缸、导轨、轴承。
- 针杆, 压脚杆使用黑金刚镀层。
- Y方向框架式连体内双轴专利设计, 运行稳顺。
- Patented appearance, beautiful and unique.
- The vertical hook base and the casing are integrated into the design, which is high-precision.
- Use high-quality solenoid valves, belts, air cylinders, guide rails, bearings and other accessories.
- The needle bar and presser foot bar are coated with black DLC coating.
- Vertical frame-type integrated dual axis patented design ensures smooth operation.
- 电镀不锈钢4mm大针板, 电镀底托。
- 双层加厚防尘板, 降噪静音。
- 断线检测, 护目镜。
- 快速换模七字铁。
- Electroplated stainless steel 4mm needle plate, electroplated bottom bracket.
- Double-layer thickened dust-proof board with obvious noise reduction effect.
- Thread breakage detection, provision of goggles.
- Quick Die Change.

技术参考

TECHNICAL PARAMETERS

型号 model	平缝 Lockstitch	线芯直径 Bobbin	缝制面积 Sewing area	针距 Stitch length
R3520K R3525K	★	25mm	35×20/35×20cm	0.1-12.7mm
	✂️ 切线装置 Thread cutting device	🧹 扫线装置 Thread wiping device	🏎️ 最高缝纫速度 Maximum speed	🌬️ 空气消耗量 Air consumption
	★	★	2,800针/分钟 2,800 rpm	



范围限制 Sewing range	X: 35cm, Y: 20cm / X: 35cm, Y: 25cm
最高缝速 Maximum sewing speed	2,800rpm
缝速设定 Sewing speed setting	9阶段设定 200-2,800rpm
针距 Stitch length	0.1-12.7mm
线迹形式 Stitch type	单针锁式线迹 Single needle lockstitch
最多针数 Maximum number of stitches	20,000 针 / 图形 20,000 stitches/pattern
存储容量 Storage capacity	900 图形 (控制箱内存) 900 patterns (control panel memory)
资料存储方式 Data storage mode	Control panel memory, USB flash disk (Not an accessory to the machine)
针杆行程 Pin stroke	40.0mm
天杆行程 Balance stroke	72.7mm
机针 Needle model	DPX17
扫线器 Thread wiping device	前后扫动式 Front and back sweeping mode
中压脚提升量 Medium presser foot lift	15mm (default set 12mm)
中压脚上下行程 Medium presser foot vertical stroke	4-10mm (default set 4mm)
上压板上行程 Upper pressure plate rise	35mm
梭床 Shuttle	自动剪线梭床 Auto thread trimming shuttle
梭壳 Bobbin case	内附防止空转弹片专用梭壳 Prevent idling shrapnel
梭芯 Bobbin	自动剪线用铁制品梭芯 Iron bobbin for auto thread cutting
剪线方式 Thread cutting device	固定刀、活动刀回转咬合式 Fixed knife and movable knife
给油方式 Oil feeding mode	注入油盒内经油芯给油式 Oiling the oil box and feed through the oil core
使用油 Oil type	白色锭子油 White spindle oil
X-Y 驱动结构 X-Y drive structure	步进马达响应控制 定时皮带传动方式
外部尺寸 External dimension	1,200mm(W) x 1,068mm(L) x 1,230mm(H) 不含线架
总重量 Gross weight	168.5kg
主轴马达型号 Spindle motor type	XL-K756-20
电源 Power	200-240V (standard feature) 110-120V, 380V-415V A converter is required (Not an accessory to the machine)

RG3520K / G3525K

直驱连体内双轴电脑花样机

Direct Drive Integrated Dual Axis Programmable Electronic Pattern Sewing Machine



RG3520/G3525/3520/3525

直驱连体内双轴电脑花样机

Direct Drive Integrated Dual Axis Programmable Electronic Pattern Sewing Machine

产品介绍

PRODUCT INTRODUCTION

- 专利外观, 新颖独特。
- 首创Y方向框架式连体内双轴专利设计, Y方向皮带中心传动专利设计。
- 运行精准、平稳、降噪、震动小, 缝制线迹更美观。
- 主轴皮带传动去除张紧轮设计专利, 传送运行更精准稳定。
- Patented appearance, beautiful and unique.
- Vertical frame-type integrated dual axis patented design ensures smooth operation. It also has low noise and vibration, and the sewing stitches are more beautiful.
- Design patent: The main shaft belt drive eliminates the tension wheel, making the transmission operation more accurate and stable.

技术参考

TECHNICAL PARAMETERS

型号 model	平缝 Lockstitch	线芯直径 Bobbin	缝制面积 Sewing area	针距 Stitch length
RG3520 R3525	★	25mm	35×20/35×25cm	0.1-12.7mm
	✂️ 切线装置 Thread cutting device	🧹 扫线装置 Thread wiping device	🏎️ 最高缝纫速度 Maximum speed	🌬️ 空气消耗量 Air consumption
	★	★	2,800针/分钟	



范围限制 Sewing range	X: 30cm, Y: 20cm / X: 35cm, Y: 25cm
最高缝速 Maximum sewing speed	2,800rpm
缝速设定 Sewing speed setting	9阶段设定 200-2,800rpm
针距 Stitch length	0.1-12.7mm
线迹形式 Stitch type	单针锁式线迹 Single needle lockstitch
最多针数 Maximum number of stitches	20,000 针 / 图形 20,000 stitches/pattern
存储容量 Storage capacity	900 图形 (控制箱内存) 900 patterns (control panel memory)
资料存储方式 Data storage mode	Control panel memory, USB flash disk (Not an accessory to the machine)
针杆行程 Pin stroke	40.0mm
天杆行程 Balance stroke	72.7mm
机针 Needle model	DPX17
扫线器 Thread wiping device	前后扫动式 Front and back sweeping mode
中压脚提升量 Medium presser foot lift	15mm (default set 12mm)
中压脚上下行程 Medium presser foot vertical stroke	4-10mm (default set 4mm)
上压板上行程 Upper pressure plate rise	35mm
梭床 Shuttle	自动剪线梭床 Auto thread trimming shuttle
梭壳 Bobbin case	内附防止空转弹片专用梭壳 Prevent idling shrapnel
梭芯 Bobbin	自动剪线用铁制品梭芯 Iron bobbin for auto thread cutting
剪线方式 Thread cutting device	固定刀、活动刀回转咬合式 Fixed knife and movable knife
给油方式 Oil feeding mode	注入油盒内经油芯给油式 Oiling the oil box and feed through the oil core
使用油 Oil type	白色锭子油 White spindle oil
X-Y 驱动结构 X-Y drive structure	步进马达响应控制 定时皮带传动方式
外部尺寸 External dimension	1,200mm(W) x 1,068mm(L) x 1,230mm(H) 不含线架
总重量 Gross weight	168.5kg
主轴马达型号 Spindle motor type	XL-K756-20
电源 Power	200-240V (standard feature) 110-120V, 380V-415V A converter is required (Not an accessory to the machine)

R3020T/3520T/3525T

直驱连体内双轴电脑花样机

Direct Drive Integrated Dual Axis Programmable Electronic Pattern Sewing Machine

RG5030K / R5030K

直驱连体内双轴电脑花样机

Direct Drive Integrated Dual Axis Programmable Electronic Pattern Sewing Machine

产品介绍

PRODUCT INTRODUCTION

- 专利外观, 美观独特。
- Y皮带挂钩座与机壳一体设计, 高精度。
- 采用高品质电磁阀、皮带、气缸、导轨、轴承。
- 针杆, 压脚杆使用黑金刚镀层。
- Y方向框架式连体内双轴专利设计, 运行稳顺。
- 飞机架结构放料更方便。
- Patented appearance, beautiful and unique.
- The vertical hook base and the casing are integrated into the design, which is high-precision.
- Use high-quality solenoid valves, belts, air cylinders, guide rails, bearings and other accessories.
- The needle bar and presser foot bar are coated with black DLC coating.
- Vertical frame-type integrated dual axis patented design ensures smooth operation.
- The aircraft frame structure is more convenient for loading materials.
- 电镀不锈钢4mm大针板, 电镀底托。
- 双层加厚防尘板, 降噪静音。
- 断线检测, 护目镜。
- 快速换模七字铁。
- 加宽底座, X,Y三导轨设计, 送料更平稳。
- Electroplated stainless steel 4mm needle plate, electroplated bottom bracket.
- Double-layer thickened dust-proof board with obvious noise reduction effect.
- Thread breakage detection, provision of goggles.
- Quick Die Change.
- Widen the base for smoother feeding.

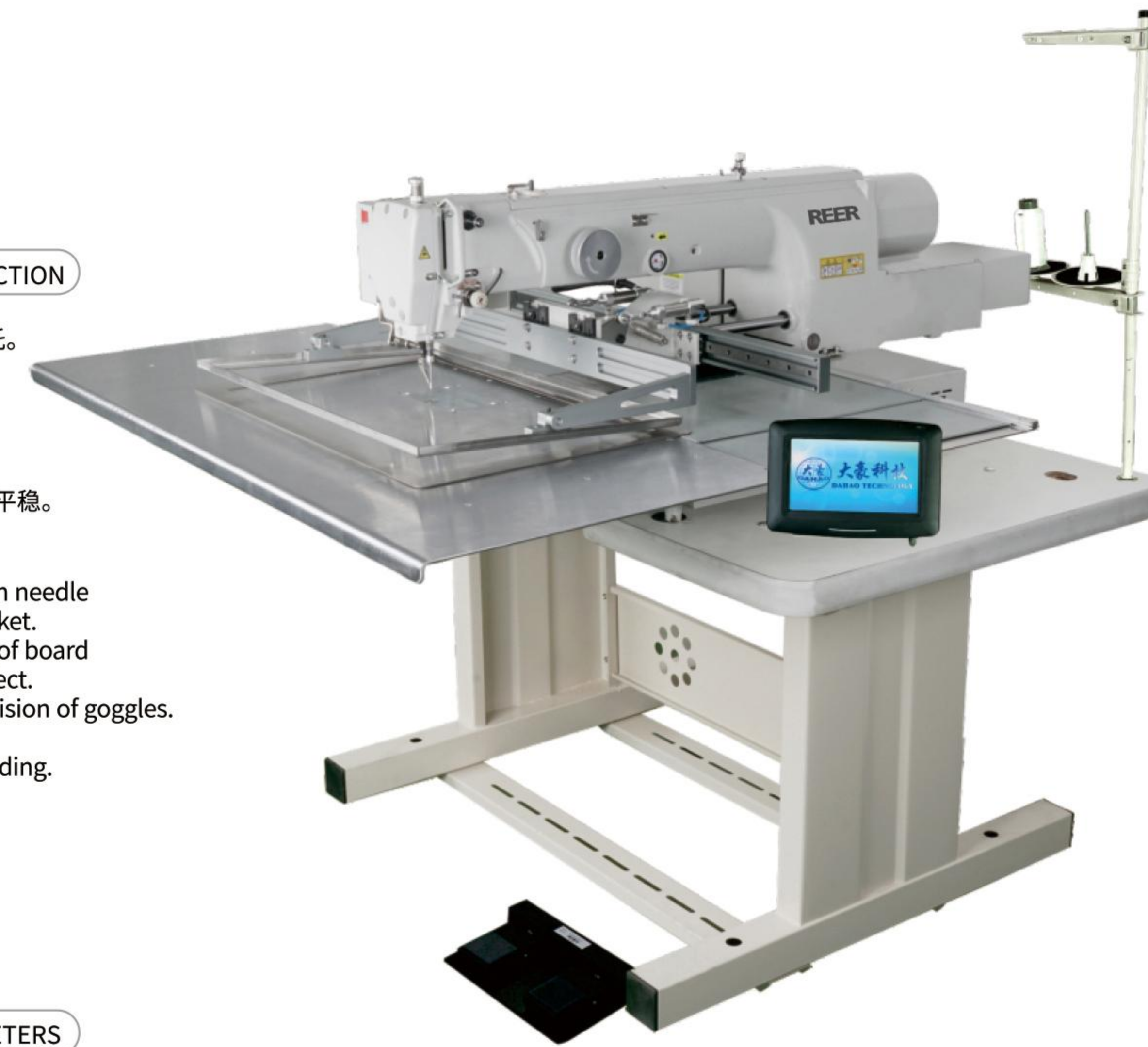

技术参考

TECHNICAL PARAMETERS

型号 model	平缝 Lockstitch	线芯直径 Bobbin	缝纫面积 Sewing area	针距 Stitch length
RG5030K R5030K	★	25mm	40×30cm	0.1-12.7mm
	✂️	🧵	🏎️	🌬️
	★	★	2,800针/分钟 2,800 rpm	



范围限制 Sewing range	X: 40cm, Y: 30cm
最高缝速 Maximum sewing speed	2,800rpm
缝速设定 Sewing speed setting	9阶段设定 200~2,800rpm
针距 Stitch length	0.1-12.7mm
线迹形式 Stitch type	单针锁式线迹 Single needle lockstitch
最多针数 Maximum number of stitches	20,000针 / 图形 20,000 stitches/pattern
存储容量 Storage capacity	900图形 (控制箱内存) 900 patterns (control panel memory)
资料存储方式 Data storage mode	Control panel memory, USB flash disk (Not an accessory to the machine)
针杆行程 Pin stroke	40.0mm
天秤行程 Balance stroke	72.7mm
机针 Needle model	DPX17
扫线器 Thread wiping device	前后扫动式 Front and back sweeping mode
中压脚提升量 Medium presser foot lift	15mm (default set 12mm)
中压脚上下行程 Medium presser foot vertical stroke	4-10mm (default set 4mm)
上压板上行程 Upper pressure plate rise	35mm
梭床 Shuttle	自动剪线梭床 Auto thread trimming shuttle
梭壳 Bobbin case	内附防止空转弹片专用梭壳 Prevent idling shrapnel
梭芯 Bobbin	自动剪线用铁制品梭芯 Iron bobbin for auto thread cutting
剪线方式 Thread cutting device	固定刀、活动刀回转咬合式 Fixed knife and movable knife
给油方式 Oil feeding mode	注入油箱内经油芯给油式 Oiling the oil box and feed through the oil core
使用油 Oil type	白色锭子油 White spindle oil
X-Y驱动结构 X-Y drive structure	步进马达响应控制 定时皮带传动方式
外部尺寸 External dimension	1,200mm(W) x 1,068mm(L) x 1,230mm(H) 不含线架
总重量 Gross weight	168.5kg
主轴马达型号 Spindle motor type	XL-K756-20
电源 Power	200-240V (standard feature) 110-120V, 380V-415V A converter is required (Not an accessory to the machine)

RG4030 / R4030

直驱连体内双轴电脑花样机

Direct Drive Integrated Dual Axis Programmable Electronic Pattern Sewing Machine

RG6040K / R6040K

直驱式大范围电脑花样机

Direct Drive Large Area Programmable Electronic Pattern Sewing Machine

产品介绍

PRODUCT INTRODUCTION

- 专利外观, 新颖独特。
- 采用高品质电磁阀、气缸、导轨、轴承。
- 针杆, 压脚杆使用黑金刚镀层。
- Patented appearance, beautiful and unique.
- Use high-quality solenoid valves, belts, air cylinders, guide rails, bearings and other accessories.
- The needle bar and presser foot bar are coated with black DLC coating.
- 电镀不锈钢4mm大针板, 电镀底托。
- 断线检测, 护目镜。
- 高性价比, 可定制更大范围。
- Electroplated stainless steel 4mm needle plate, electroplated bottom bracket.
- Thread breakage detection, provision of goggles.
- This machine is cost-effective and can be customized for a larger sewing range.



技术参考

TECHNICAL PARAMETERS

型号 model	平缝 Lockstitch	线芯直径 Bobbin	缝纫面积 Sewing area	针距 Stitch length
RG5030K R6040K	★	25mm	60×40cm	0.1-12.7mm
	✂️	🧵	🏎️	🌬️
	★	★	2,500针/分钟 2,500 rpm	



范围限制 Sewing range	X: 60cm, Y: 40cm
最高缝速 Maximum sewing speed	2,800rpm
缝速设定 Sewing speed setting	9阶段设定 200~2,800rpm
针距 Stitch length	0.1-12.7mm
线迹形式 Stitch type	单针锁式线迹 Single needle lockstitch
最多针数 Maximum number of stitches	20,000针 / 图形 20,000 stitches/pattern
存储容量 Storage capacity	900图形 (控制箱内存) 900 patterns (control panel memory)
资料存储方式 Data storage mode	Control panel memory, USB flash disk (Not an accessory to the machine)
针杆行程 Pin stroke	40.0mm
天秤行程 Balance stroke	72.7mm
机针 Needle model	DPX17
扫线器 Thread wiping device	前后扫动式 Front and back sweeping mode
中压脚提升量 Medium presser foot lift	15mm (default set 12mm)
中压脚上下行程 Medium presser foot vertical stroke	4-10mm (default set 4mm)
上压板上行程 Upper pressure plate rise	35mm
梭床 Shuttle	自动剪线梭床 Auto thread trimming shuttle
梭壳 Bobbin case	内附防止空转弹片专用梭壳 Prevent idling shrapnel
梭芯 Bobbin	自动剪线用铁制品梭芯 Iron bobbin for auto thread cutting
剪线方式 Thread cutting device	固定刀、活动刀回转咬合式 Fixed knife and movable knife
给油方式 Oil feeding mode	注入油箱内经油芯给油式 Oiling the oil box and feed through the oil core
使用油 Oil type	白色锭子油 White spindle oil
X-Y驱动结构 X-Y drive structure	步进马达响应控制 定时皮带传动方式
外部尺寸 External dimension	1,200mm(W) x 1,068mm(L) x 1,230mm(H) 不含线架
总重量 Gross weight	168.5kg
主轴马达型号 Spindle motor type	XL-K756-20
电源 Power	200-240V (standard feature) 110-120V, 380V-415V A converter is required (Not an accessory to the machine)

RG6040 / R6040

直驱式大范围电脑花样机

Direct Drive Large Area Programmable Electronic Pattern Sewing Machine

RX4040/RX3040

直驱式小嘴电脑花样机

Direct Drive Small Cylinder Bed Programmable Electronic Pattern Sewing Machine

产品介绍

PRODUCT INTRODUCTION

- 专利外观, 美观独特。
- Y方向40cm长5cm宽长嘴设计。
- 电镀不锈钢4mm大针板, 电镀底托。
- 断线检测, 护目镜。
- 性价比高, 可定制更大范围。
- Patented appearance, beautiful and unique.
- Vertically position 40cm long and 5cm wide with a long cylinder bed design.
- Electroplated stainless steel 4mm needle plate, electroplated bottom bracket.
- Thread breakage detection, provision of goggles.
- This machine is cost-effective and can be customized for a larger sewing range.

技术参考

TECHNICAL PARAMETERS

型号 model	平缝 Lockstitch	线芯直径 Bobbin	缝纫面积 Sewing area	针距 Stitch length
R3040 R4040	★	25mm	40×40cm	0.1-12.7mm
	✂️ 切线装置 Thread cutting device	🧹 扫线装置 Thread wiping device	🏃 最高缝纫速度 Maximum speed	🌬️ 空气消耗量 Air consumption
	★	★	2,800针/分钟 2,800 rpm	—

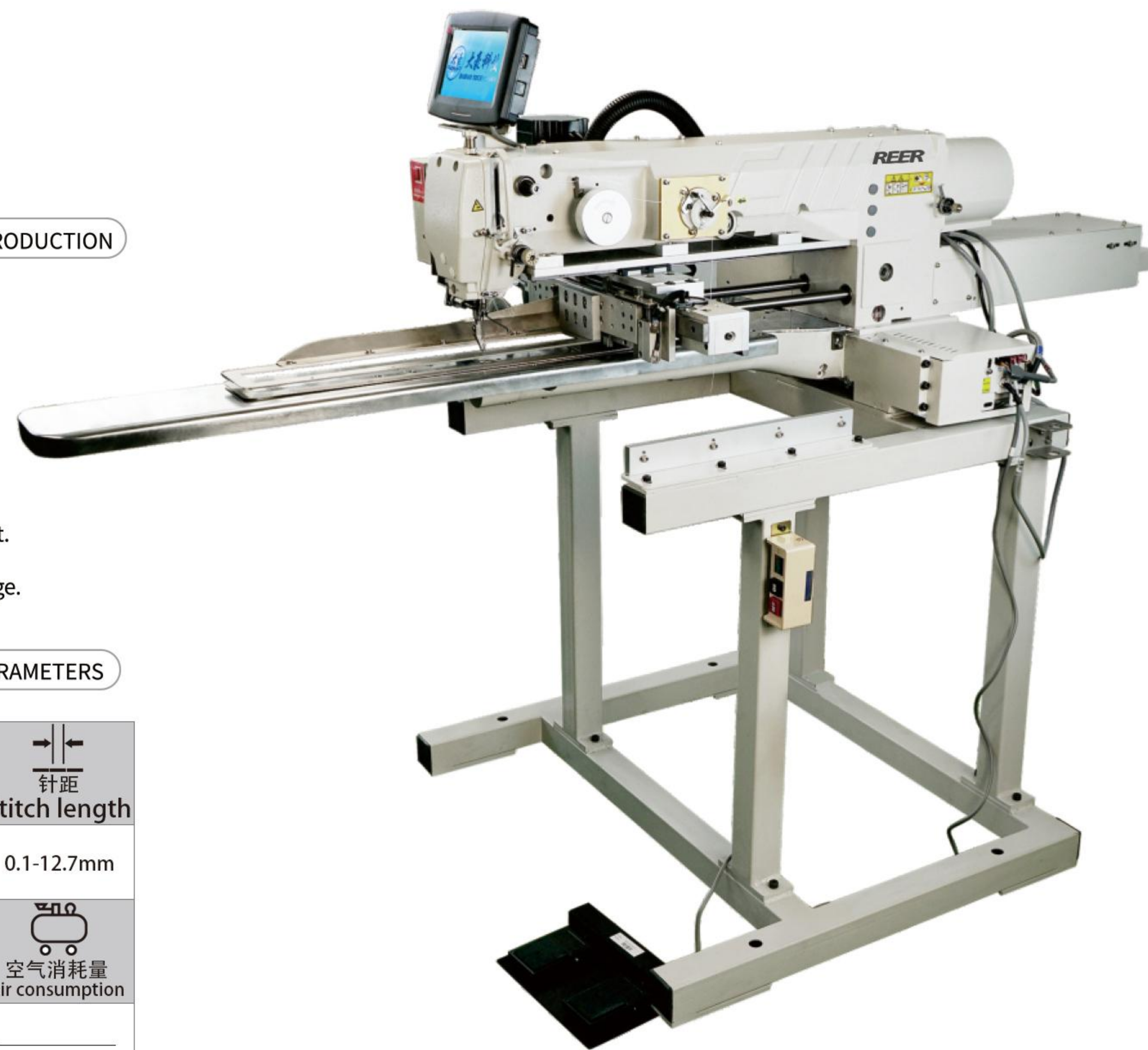

机器型号	Machine type	JL-311G/326G
缝纫范围	Sewing range	220mm*100mm
缝纫形式	Sewing form	单针平缝 Single-needle flat seam
旋梭种类	Rotary shuttle type	半转2倍旋梭 Half turn double spindle
最高缝纫速度	Maximum sewing speed	2700rpm
送料方式	Feeding method	间歇或连续送料(可切换) Intermittent or continuous feeding (switchable)
线迹缝距	Stitch spacing	0.05-12.7mm
最大针数	Maximum number of	20,000/花样Pattern
最大花样存储数	Largest pattern storage	900
记忆媒介	Memory media	USB
压脚提升量	Pressure foot lift	气动25mm/脉动30mm Pneumatic 25mm/ pulsation 30mm
抬压脚驱动方式	Lift pressure foot drive mode	气动式脉动式马达 Pneumatic/ Pulsating motor type
中压脚方式	Medium pressure foot method	伺服驱动 Servo drive
中压脚提升量	Medium pressure foot lift stroke	15mm
中压脚行程	Medium pressure foot	4-10mm
针杆行程	Needle bar stroke	40mm
使用机针	Use the needle	DP×17#18#
X-Y驱动结构	X-Ydrive structure	皮带传动方式 Belt transmission mode
切线/扫线装置	Tangent/sweep device	标准装置 Standard device
电源	Power	单相100/220v、3相200v/220v 380v/400v/400va

R311G/R326G

直驱电脑花样机

Direct Drive Programmable Electronic Pattern Sewing Machine

R430D

电脑直驱式平缝打结机

Direct Drive Bar Tacking Lockstitch Sewing Machine (Sewing Area: 40*30mm)

产品介绍

PRODUCT INTRODUCTION

转速为业内最高

最高转速3,200RPM。完全按照缝制数据进行高质量缝纫。
World's top-class sewing speed of 3,200rpm with high quality sewing. Superior usability as everyone can use easily and reliability.

缝制区域40X30mm

可用于从男装/女装到牛仔布、针织物/女式内衣的各种不同用途。
Sewing area 40*30mm. Suitable for sewing medium-thick materials such as garment, denim fabrics etc.

低噪音/低震动

采用了刚性较高的机架。通过最新电脑的分析, 部件的各个细节部分之间都取得了良好的平衡, 噪音及震动抑制到最低限度, 操作人员不易疲劳, 也不会感到压力。
Low noise/Low vibration. The combination of high-quality steel frame and precision accessories greatly reduces the noise of machine operation, makes workers less fatigued when using the machine, and improves work efficiency.



技术参考

TECHNICAL PARAMETERS

型号 Model	最大转速 Max. Sewing Speed	针轨长度 Stitch length	压脚高度 Presser foot lift height	机针型号 Needle model
R430D	3200r/min	0~11mm	14mm	DP×17



技术参考

TECHNICAL PARAMETERS

型号 model	平缝 Lockstitch	线芯直径 Bobbin Diameter	缝纫面积 Sewing Area (XY)	针距 Stitching Length
R0906	★	21mm	90×60mm	0.1-7mm
	✂️ 切线装置 Thread Trimmer	🧹 扫线装置 Thread Wiper	🏃 最高缝纫速度 Max. Sewing Speed	🌬️ 空气消耗量 Air Pressure Consumption
	★	★	3,200针/分钟	—



R0906

小型花样机

Direct Drive Lockstitch Pattern Tacking Sewing Machine (Sewing Area: 90*60mm)

R246-C /R246D1-C

加长型筒式综合送料小嘴高车

Long Arm Cylinder Bed Walking Foot Lockstitch Sewing Machine (Cylinder Diameter: 50mm)



产品介绍

PRODUCT INTRODUCTION

- 可定制各种尺寸, 满足多样性市场需求。
- 本机设计采用大旋梭小筒形缝台, 综合送料&同步式水平移动包边装置。
- 机器外观设计新颖, 操作调节方便, 缝纫线迹美观均衡, 工作效率出众。
- 小直径筒形缝台, 广泛应用于各类真皮、皮革、鞋帽、足球、坐垫、手袋、箱包、玩具、包装箱的明线缝纫&包边缝纫。
- Arm length size can be customized: 480/600/800/1000mm.
- Large capacity bobbin, 50mm diameter cylinder size, compound walking foot feed mechanism, synchronous horizontal moving binding folder device for selection.
- Beautiful appearance, easy operation, stable stitching, outstanding efficiency.
- Suitable for sewing medium to thick materials such as women bags, wallets, footballs, mats, toys, hats, luggage bags, leather materials and more. Good for normal sewing or binding sewing.

技术参考

TECHNICAL PARAMETERS

型号 Model	转速 Max. sewing speed	针轨长度 Stitch length	压脚高度 Presser foot lift height	机针型号 Needle model	筒径 Cylinder diameter
R246D1-C R246D3-C	2000r/min	0~9mm	15mm	DP×17	50mm



R246D1-2AD

筒式综合送料直驱电脑小嘴高车

Direct Drive Cylinder Bed Walking Foot Lockstitch Sewing Machine (Cylinder Diameter: 50mm)

产品介绍

PRODUCT INTRODUCTION

- 专利外观, 美观新颖。
- 电动抬压脚、电动倒缝装置, 省力高效。
- 自动供油、自动绕线芯、上下定针功能。
- 直驱一体伺服电机, 低能耗, 低噪音, 低震动, 节能环保。
- 小直径筒形缝台, 广泛应用于各类真皮、皮革、鞋帽、足球、坐垫、手袋、箱包、玩具、包装箱的明线缝纫&包边缝纫。
- Patent appearance, beautiful and novel.
- Electric presser foot lift & electric reverse stitching are more labor-saving and efficient.
- Automatic oil supply, automatic winding threads, needle position functions.
- Direct drive servo motor: low energy consumption, low noise, more energy-saving and eco-friendly.
- Suitable for sewing medium to thick materials such as women bags, wallets, footballs, mats, toys, hats, luggage bags, leather materials and more. Good for normal sewing or binding sewing.

技术参考

TECHNICAL PARAMETERS

型号 Model	转速 Max. sewing speed	针轨长度 Stitch length	压脚高度 Presser foot lift height	机针型号 Needle model	筒径 Cylinder diameter
R246D1-2AD	2000r/min	0~9mm	15mm	DP×17	50mm

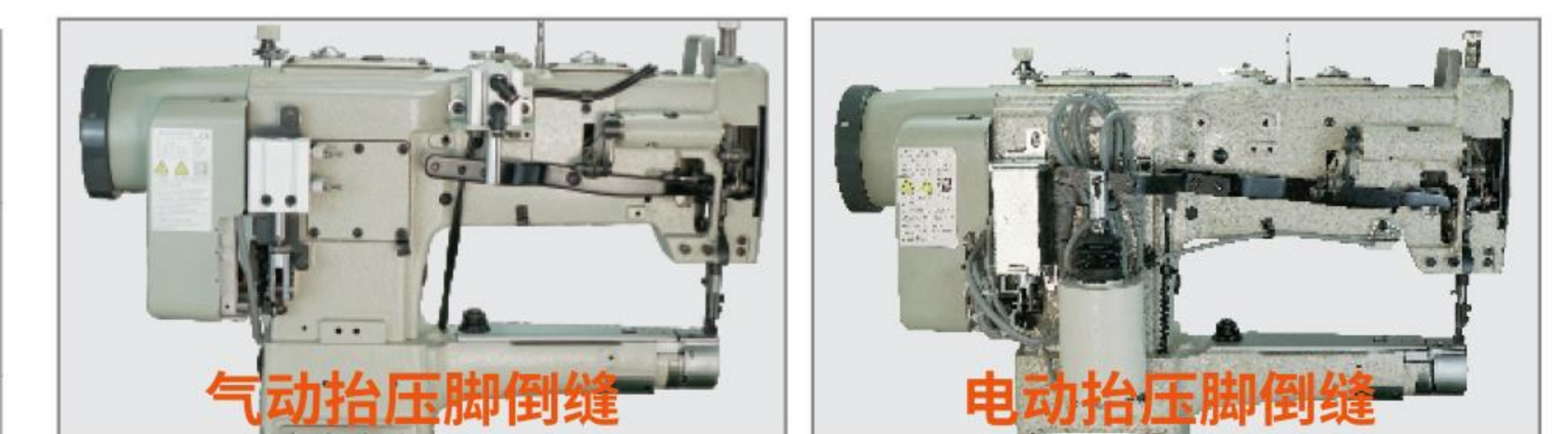

R246D-2A /R246VD3-2A

筒式综合送料直驱电脑小嘴高车

Direct Drive Cylinder Bed Walking Foot Lockstitch Sewing Machine (Cylinder Diameter: 50mm)

R246-2/R246-2A

筒式综合送料小嘴高车

Cylinder Bed Walking Foot Lockstitch Sewing Machine
(Cylinder Diameter: 50mm)

产品介绍

PRODUCT INTRODUCTION

- 本机设计采用小筒形缝台，综合送料&同步式水平移动包边装置。
- 机器外观设计新颖，操作调节方便，缝纫线迹美观均衡，工作效率出众。
- 小直径筒形缝台，广泛应用于各类真皮、皮革、鞋帽、足球、坐垫、手袋、箱包、玩具、包装盒的明线缝纫&包边缝纫。
- This machine design adopts 50mm small diameter cylinder sewing table, compound walking foot feed mechanism and synchronous horizontal moving binding folder device.
- Beautiful appearance, easy operation, stable stitching, outstanding efficiency.
- Suitable for sewing medium to thick materials such as women bags, wallets, footballs, mats, toys, hats, luggage bags, leather materials and more. Good for normal sewing or binding sewing.



技术参考

TECHNICAL PARAMETERS

型号 Model	转速 Max. sewing speed	针轨长度 Stitch length	压脚高度 Presser foot lift height	机针型号 Needle model	筒径 Cylinder diameter
R 246D-2 R 246-2A	2200r/min	0-9mm	15mm	DP×17	50mm

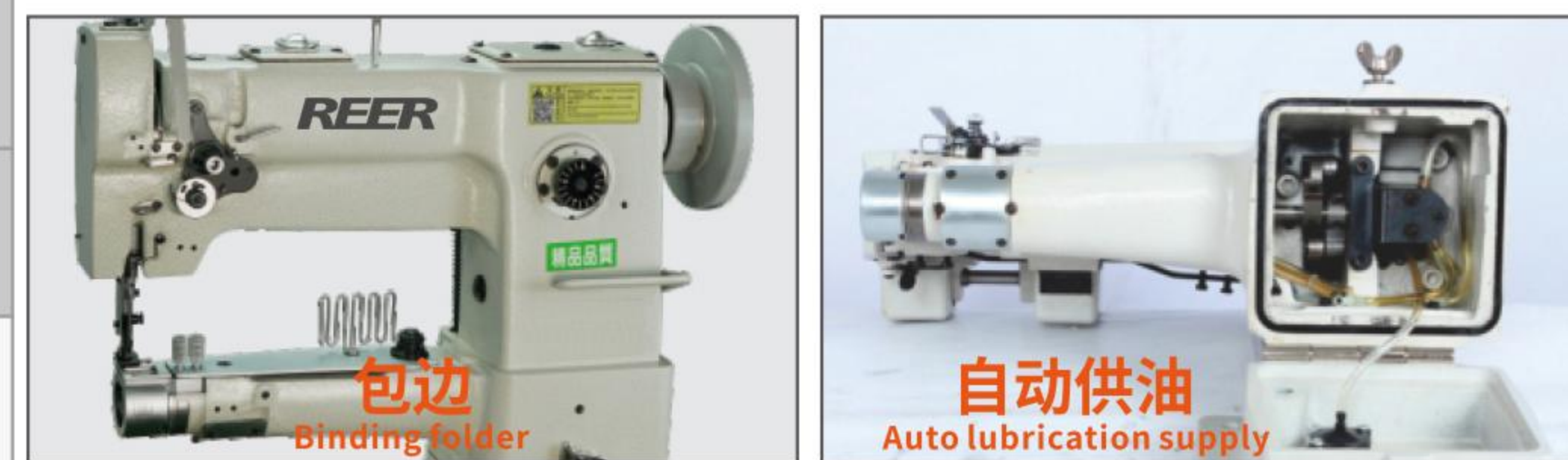

(红衫电控)

透明可移动桌板 (48*39mm)
Moveable flat bed attachment table



R246D3-2A

R246D3/R246V-2

筒式综合送料&同步式水平送料小嘴高车

Cylinder Bed Walking Foot Lockstitch Sewing Machine
(Cylinder Diameter: 50mm).

R246/R246-A

筒式综合送料小嘴高车

Cylinder Bed Walking Foot Lockstitch Sewing Machine
(Cylinder Diameter: 50mm).

产品介绍

PRODUCT INTRODUCTION

- 本机设计采用小筒形缝台，综合送料&同步式水平移动包边装置。
- 机器外观设计新颖，操作调节方便，缝纫线迹美观均衡，工作效率出众。
- 小直径筒形缝台，广泛应用于各类真皮、皮革、鞋帽、足球、坐垫、手袋、箱包、玩具、包装盒的明线缝纫&包边缝纫。
- This machine design adopts 50mm small diameter cylinder sewing table, compound walking foot feed mechanism and synchronous horizontal moving binding folder device.
- Beautiful appearance, easy operation, stable stitching, outstanding efficiency.
- Suitable for sewing medium to thick materials such as women bags, wallets, footballs, mats, toys, hats, luggage bags, leather materials and more. Good for normal sewing or binding sewing.



技术参考

TECHNICAL PARAMETERS

型号 Model	转速 Max. sewing speed	针轨长度 Stitch length	压脚高度 Presser foot lift height	机针型号 Needle model	筒径 Cylinder diameter
R246 R246V	2200r/min	0-9mm	15mm	DP×17	50mm



(红衫电控)



R246V-A

R246D3/R246V

筒式综合送料&同步式水平送料小嘴高车

Cylinder Bed Walking Foot Lockstitch Sewing Machine
(Cylinder Diameter: 50mm)

R244D1-2AD

筒式综合送料直驱电脑小嘴高车
Direct Drive Cylinder Bed Walking Foot Lockstitch Sewing Machine (Cylinder Diameter: 47.5mm)

产品介绍

PRODUCT INTRODUCTION

- 可选气动、电动抬压脚倒缝装置，省力高效。
- 自动供油、自动绕线芯、上下定针功能。
- 直驱一体伺服电控，低能耗，低噪音，低震动，节能环保。
- 小直径筒形缝台，广泛应用于各类真皮、皮革、鞋帽、足球、坐垫、手袋、箱包、玩具、包装盒的明线缝绉&包边缝绉。
- Electric presser foot lift & electric reverse stitching are more labor-saving and efficient.
- Automatic oil supply, automatic winding thread, needle position functions.
- Direct drive servo motor: low energy consumption, low noise, more energy-saving and eco-friendly.
- Suitable for sewing medium to thick materials such as women bags, wallets, footballs, mats, toys, hats, luggage bags, leather materials and more. Good for normal sewing or binding sewing.

技术参考

TECHNICAL PARAMETERS

型号 Model	转速 Max. sewing speed	针轨长度 Stitch length	压脚高度 Presser foot lift height	机针型号 Needle model	筒径 Cylinder diameter
R244-2 R244D1-2A	2200r/min	0-9mm	15mm	DP×17	47.5mm

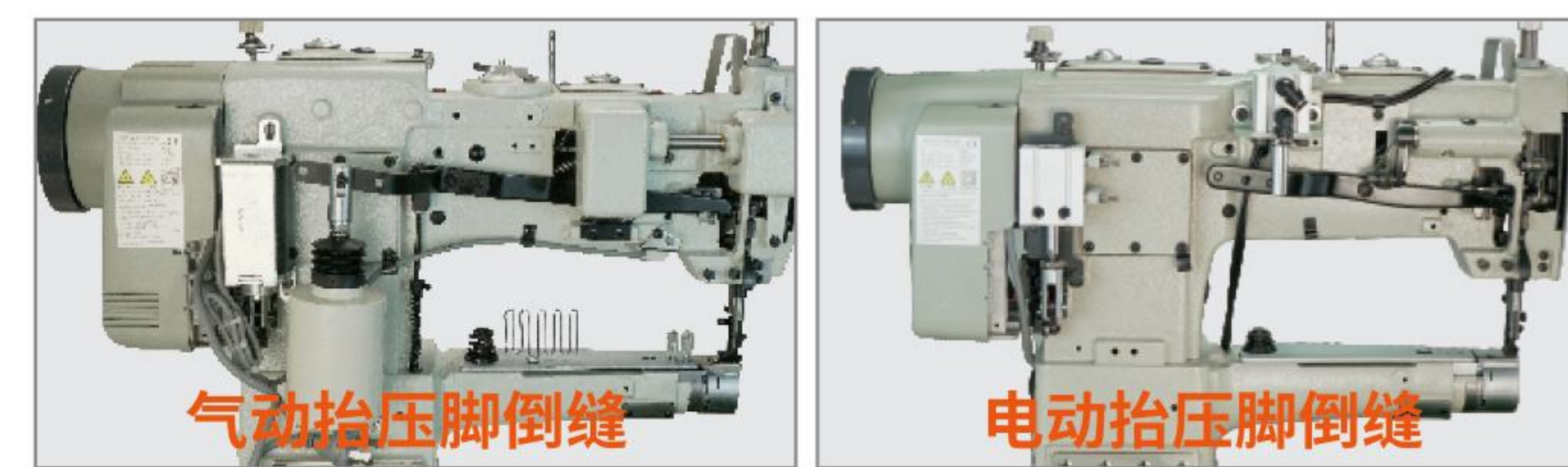

(红杉电控)



R244D3-2/R244V-2
筒式综合送料&同步式水平送料小嘴高车
Direct Drive Cylinder Bed Walking Foot Lockstitch Sewing Machine
(Cylinder Diameter: 47.5mm)

R244/R244-A

筒式综合送料小嘴高车
Cylinder Bed Walking Foot Lockstitch Sewing Machine (Cylinder Diameter: 47.5mm)

产品介绍

PRODUCT INTRODUCTION

- 本机设计采用小筒形缝台，综合送料，同步式移动包边装置。
- 机器外观设计新颖，操作调节方便，缝绉线迹美观均衡，工作效率出众。
- 小直径筒形缝台，广泛应用于各类真皮、皮革、鞋帽、足球、坐垫、手袋、箱包、玩具、包装盒的明线缝绉&包边缝绉。
- 可选40mm超小嘴盖，满足小物件特殊缝制。
- This machine design adopts 47.5mm small diameter cylinder sewing table, compound walking foot feed mechanism and synchronous horizontal moving binding folder device.
- Beautiful appearance, easy operation, stable stitching, outstanding efficiency.
- Suitable for sewing medium to thick materials such as women bags, wallets, footballs, mats, toys, hats, luggage bags, leather materials and more. Good for normal sewing or binding sewing.
- Optional 40mm ultra-small cylinder diameter cover is available for special sewing of small items.

技术参考

TECHNICAL PARAMETERS

型号 Model	转速 Max. sewing speed	针轨长度 Stitch length	压脚高度 Presser foot lift height	机针型号 Needle model	筒径 Cylinder diameter
R244 R244-A	2200r/min	0-9mm	15mm	DP×17	47.5mm



(红杉电控)



R244

R244D3/R244V
筒式综合&同步式水平送料小嘴高车
Cylinder Bed Walking Foot Lockstitch Sewing Machine
(Cylinder Diameter: 47.5mm)

R6860DT

筒式综合送料自动剪线高车

Cylinder Bed Walking Foot Lockstitch Sewing Machine (Cylinder Diameter: 70mm)

产品介绍

PRODUCT INTRODUCTION

- 外观专利设计, 新颖独特美观。
- 自动剪线、自动抬压脚、自动加固缝、自动供油、自动绕线芯、上下定针功能。
- 直驱一体式伺服电控、低能耗、超静音、少震动、节能环保。
- 适用于箱包、手袋、足球、玩具、护具等厚料缝制。
- Patent appearance, beautiful and novel.
- Automatic thread trimming, automatic presser foot lift, automatic bar tacking sew, automatic oil supply, automatic winding thread, needle position functions.
- Direct drive servo motor: low energy consumption, low noise, more energy-saving and eco-friendly.
- Suitable for sewing thick materials such as plastic suitcases, protective equipment, handbags, footballs, toys, leather materials and more.

技术参考

TECHNICAL PARAMETERS

型号 Model	转速 Max. sewing speed	针轨长度 Stitch length	压脚高度 Presser foot lift height	机针型号 Needle model	筒径 Cylinder diameter
R6860DT R6860D3	2200r/min	0-9mm 0-11mm	15mm	DP×17	70mm



(鲍麦电控)



R6860D1-Q/R6860VD1

筒式综合&水平送料直驱电脑高车
Direct Drive Cylinder Bed Walking Foot Lockstitch Sewing Machine (Cylinder Diameter: 70mm).

R1341/R1341L

筒式综合送料大嘴高车

Cylinder Bed Walking Foot Lockstitch Sewing Machine (Cylinder Diameter: 70mm)

产品介绍

PRODUCT INTRODUCTION

- 分体式摆杆、压力钢板&压杆调压螺丝双压力调节设计。
- 自动润滑设计, 降低人工保养时间, 降噪并延长零件使用寿命。
- 11mm大针距设计。
- 抬压脚膝控设计, 操作更省力。
- 最新型可调式新款牙架, 经久耐用。
- 适用于箱包、手袋、拉杆箱、汽车椅套、脚垫等中厚料缝纫。
- Using newly upgraded precision parts (new tooth rack, shuttle hook, gear etc) makes sewing more stable and easier.
- Automatic lubrication design reduces manual maintenance time, reduces noise and extends the service life of parts.
- Max stitching length 11mm.
- The lifting presser foot uses a knee pad controlled design for less effort to operate.
- Use the latest adjustable new feed dog support for durability.
- Suitable for sewing thick materials such as plastic suitcases, protective equipment, handbags, car mats/seats, heavy leather or canvas materials and more.

技术参考

TECHNICAL PARAMETERS

型号 Model	转速 Max. sewing speed	针轨长度 Stitch length	压脚高度 Presser foot lift height	机针型号 Needle model	筒径 Cylinder diameter
R1341 R21341L	2200r/min	0-11mm 0-9mm	15mm	DP×17	70mm

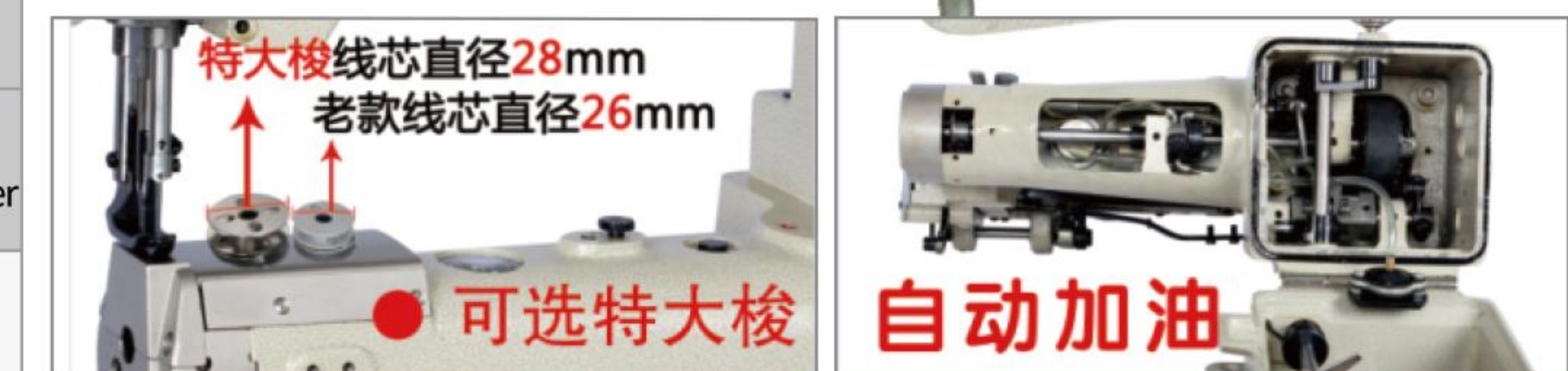

(鲍麦电控)



R21341L/R26860L-D1

筒式双针综合送料高头车
Two Needle Cylinder Bed Walking Foot Lockstitch Sewing Machine (Cylinder Diameter: 70mm).

R341 筒式综合送料大嘴高车

Cylinder Bed Walking Foot Lockstitch Sewing Machine
(Cylinder Diameter: 70mm)

产品介绍 PRODUCT INTRODUCTION

- 采用新款牙架, 双倍大旋梭和梭子, 高品质斜纹齿轮、镶铜套的梭床座、牛角、分线勾等配件。
- 专为箱包制造设计的筒式厚料平缝机, 机构坚实, 造型新颖。
- 采用滑杆挑线, 构成双线锁式线迹, 上下轴用同步齿形带传动。
- 压脚、送布牙、机针同步送料, 杠杆式针距调节机构。
- 高压脚行程, 高压脚提升间隙和9.5mm大针距设计。
- It adopts updated feed dog parts, double-capacity shuttle hook and bobbin, high-quality helical gear, copper gear and other accessories.
- Cylinder bed sewing machine specially designed for luggage manufacturing, solid mechanism and novel shape.
- The sliding rod is used to pick the thread to form a double-thread lock stitch, and the top and bottom shafts are driven by synchronous toothed belts.
- Compound feeding composed of presser foot, feeding teeth, and machine needle, with a lever type needle distance adjustment mechanism.
- Higher presser foot lift height and max stitching length is 9.5mm.

技术参考 TECHNICAL PARAMETERS

型号 Model	转速 Max. sewing speed	针轨长度 Stitch length	压脚高度 Presser foot lift height	机针型号 Needle model	筒径 Cylinder diameter
R341 R341-2	2200r/min	0-9.5mm	15mm	DP×17	70mm



(红杉电控)

(谷立电控)

R341D3-2/R341D2-2

筒式综合送料大嘴高车
Cylinder Bed Walking Foot Lockstitch Sewing Machine (Cylinder Diameter: 70mm)



R343D

R1341-C/R1341D3-C 加长型筒式综合送料高车

Long Arm Cylinder Bed Walking Foot Lockstitch Sewing Machine (Cylinder Diameter: 70mm)

产品介绍 PRODUCT INTRODUCTION

- 分体式摆杆、压力钢板&压杆调压螺丝双压力调节设计。
- 自动润滑设计, 降低人工保养时间, 降噪并延长零件使用寿命。
- 11mm大针距设计。
- 最新型可调式新款牙架, 经久耐用。
- 可选定制各种规格长度, 满足多样性市场需求。
- 适用于箱包、钓鱼竿布袋、高尔夫球袋等特殊中厚料的缝制。
- 6860SD3专为拉杆箱窗盖的缝合定制机型, 缝制速度快, 高效节能。
- Using newly upgraded precision parts (new tooth rack, shuttle hook, gear etc) makes sewing more stable and easier.
- Automatic lubrication design reduces manual maintenance time, reduces noise and extends the service life of parts.
- Max stitching length 11mm.
- Use the latest adjustable new feed dog support for durability.
- Cylinder arm length size can be customized. Available sizes: 500/600/800/1000mm.
- Suitable for sewing thick materials such as plastic suitcases, protective equipment, handbags, car mats/seats, fishing rod bags, eco-friendly ventilation tube, golf bags, heavy leather or canvas materials and more.
- The 6860SD3 is a customized model for stitching ABS plastic suitcase covers, which is fast sewing speed and energy efficient.

技术参考 TECHNICAL PARAMETERS

型号 Model	转速 Max. sewing speed	针轨长度 Stitch length	压脚高度 Presser foot lift height	机针型号 Needle model	筒径 Cylinder diameter
R1341	2200r/min	0-11mm	15mm	DP×17	70mm



可选500/600/800/1000mm



R6860SD3



R8BD3-C/R8B-C

加长型筒式综合送料高车
Long Arm Cylinder Bed Walking Foot Lockstitch Sewing Machine (Cylinder Diameter: 65mm)

产品介绍 PRODUCT INTRODUCTION

- 采用连杆式上下送料机构和压脚交替提升机构，保证送料顺畅。
- 最新款牙架设计，大大延长了使用寿命。
- 28BLD1-2A采用双针大旋梭设计，直驱马达，自动绕线芯，上下定针功能，可选气动抬压脚、倒缝。
- 可选定制各种规格长度，满足多样性市场需求。
- 适用于布袋、皮具、箱包、鞋帽、书包等中厚料的缝纫及生产中的包边工序。
- Adopting a connecting rod type upper and lower feeding structure and a presser foot alternating lifting structure to ensure smooth feeding.
- Use the latest adjustable new teeth rack for durability.
- JL-28BLD1-2A adopts double-needle large rotary hook design, direct drive servo motor, automatic winding thread, needle position functions. Optional pneumatic presser foot lift & pneumatic reserve stitching.
- Arm length size can be customized: 480/600/800/1000mm.
- Suitable for sewing thick materials such as plastic suitcases, handbags, hats, shoes, heavy leather or canvas materials and more. Good for normal sewing or binding sewing.



技术参考 TECHNICAL PARAMETERS

型号 Model	转速 Max. sewing speed	针轨长度 Stitch length	压脚高度 Presser foot lift height	机针型号 Needle model	筒径 Cylinder diameter
R8BDT R8BLD1-2A	2200r/min	0~7mm	15mm	DP×17	65mm
R8B-C R28B	2200r/min	0~7mm	15mm	DP×17	65mm



R28BLD1-2A/R28B

筒式双针综合送料高车
Two Needle Cylinder Bed Walking Foot Lockstitch Sewing Machine (Cylinder Diameter: 65mm)

R8BDT

筒式综合送料自动剪线高车
Cylinder Bed Auto Thread Trimming Walking Foot Lockstitch Machine (Cylinder Diameter: 65mm)

产品介绍 PRODUCT INTRODUCTION

- 专利设计。
- 自动剪线、自动供油、自动定针、自动抬压脚、倒缝、自动绕线芯功能。
- 直驱一体伺服电控，低能耗，少震动，节能环保。
- 8BLD1-2A采用特大旋梭设计，直驱马达，自动绕线芯，上下定针功能，可选气动抬压脚。
- 适用于布袋、皮具、箱包、鞋帽、书包等中厚料的明线缝纫及包边缝纫。
- Patent design, beautiful and novel.
- Automatic thread trimming, automatic presser foot lift and reserve stitching, automatic oil supply, automatic winding thread, needle position functions.
- Direct drive servo motor: low energy consumption, low noise, more energy-saving and eco-friendly.
- JL-8BLD1-2A adopts large capacity shuttle hook design, direct drive servo motor, automatic winding thread, needle position functions. Optional pneumatic presser foot lift & pneumatic reserve stitching.
- Suitable for sewing thick materials such as plastic suitcases, handbags, hats, shoes, heavy leather or canvas materials and more. Good for normal sewing or binding sewing.

技术参考 TECHNICAL PARAMETERS

型号 Model	转速 Max. sewing speed	针轨长度 Stitch length	压脚高度 Presser foot lift height	机针型号 Needle model	筒径 Cylinder diameter
R8BDT R8BLD1-2A	2200r/min	0~7mm	15mm	DP×17	65mm



R8BLD1-2A/R38BD-2

筒式综合送料直驱电脑高车
Direct Drive Cylinder Bed Walking Foot Lockstitch Sewing Machine (Cylinder Diameter: 65mm)

R8B-2/R8B-2A

筒式综合送料高车

Cylinder Bed Walking Foot Lockstitch Sewing Machine (Cylinder Diameter: 65mm)

产品介绍

PRODUCT INTRODUCTION

- 采用连杆式上下送料机构和压脚交替提升机构,保证送料顺畅。
- 采用自动润滑装置,最高速度可达2200转/分钟。
- 最新款牙架设计,大大延长了使用寿命。
- 8BLD3-2A采用特大旋梭设计,直驱马达,自动绕线芯,上下定针功能,可选气动抬压脚。
- 适用于包袋、皮具、箱包、鞋帽、书包等中厚料的缝纫及生产中的包边工序。
- Adopting a connecting rod type upper and lower feeding structure and a presser foot alternating lifting structure to ensure smooth feeding.
- Automatic lubrication supply, the maximum speed can reach 2,200 rpm.
- Use the latest adjustable new feed dog support for durability.
- JL-8BLD3-2 adopts large capacity shuttle hook design, direct drive servo motor, automatic winding thread, needle position functions. Optional pneumatic presser foot lift & pneumatic reserve stitching.
- Suitable for sewing thick materials such as plastic suitcases, handbags, hats, shoes, heavy leather or canvas materials and more. Good for normal sewing or binding sewing.

技术参考

TECHNICAL PARAMETERS

型号 Model	转速 Max. sewing speed	针轨长度 Stitch length	压脚高度 Presser foot lift height	机针型号 Needle model	筒径 Cylinder diameter
R8B-2 R8BLD3-2	2200r/min	0~7mm	15mm	DP×17	65mm

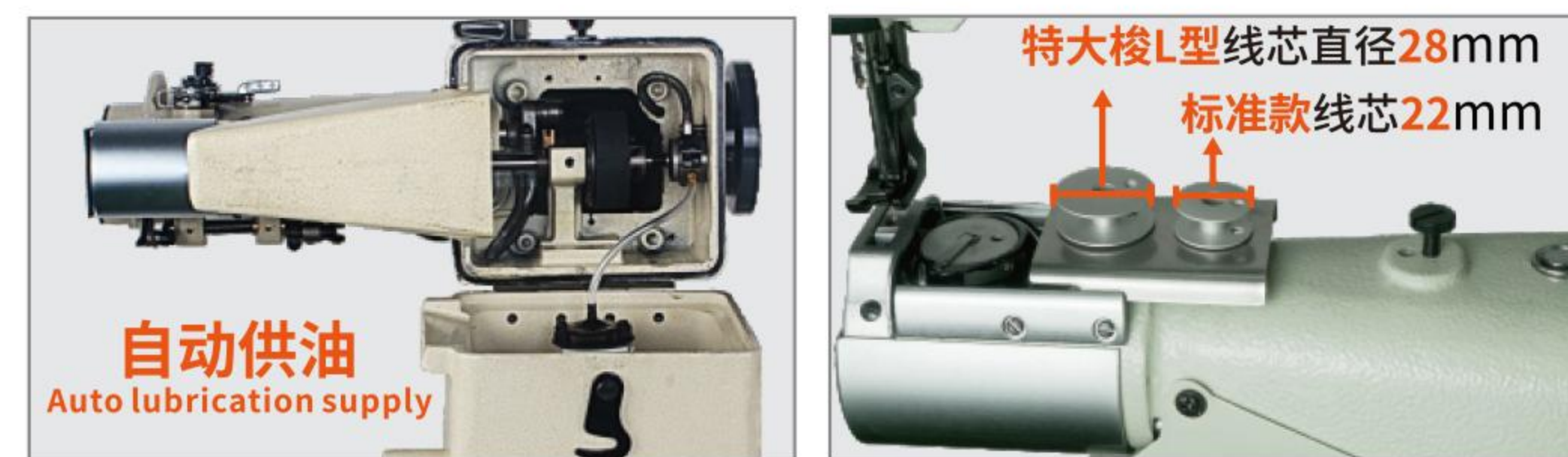

(红杉电控)



大梭28mm线芯
Large shuttle (28MM core)

R8BLD3-2A

R8B-2/R8BLD3-2

筒式综合送料单直驱高车

Cylinder Bed Walking Foot Lockstitch Sewing Machine (Cylinder Diameter: 65mm)

R8B/R8B-A

筒式综合送料标准旋梭高车

Cylinder Bed Walking Foot Lockstitch Sewing Machine (Standard bobbin diameter 22mm)

产品介绍

PRODUCT INTRODUCTION

- 本机是专为箱包、手袋、书包制造设计的筒式厚料平缝机。
- 采用滑杆挑线,构成双线锁式线迹,上下轴用同步齿形带传动。
- 压脚、送布牙、机针同步送料,杠杆式针距调节机构。
- 高压脚行程,高压脚提升间隙设计。
- 适用于箱包、手袋、旅行箱、床垫、书包的缝纫及包边作业。
- Cylinder bed sewing machine specially designed for luggage manufacturing, solid mechanism and novel shape.
- The sliding rod is used to pick the thread to form a double-thread lock stitch, and the top and bottom shafts are driven by synchronous toothed belts.
- Compound feeding composed of pressure foot, feeding teeth, and machine needle, with a lever type needle distance adjustment mechanism.
- Higher presser foot lifting height.
- Suitable for sewing thick materials such as plastic suitcases, mattress, handbags, schoolbag, leather materials and more. Good for normal sewing or binding sewing.

技术参考

TECHNICAL PARAMETERS

型号 Model	转速 Max. sewing speed	针轨长度 Stitch length	压脚高度 Presser foot lift height	机针型号 Needle model	筒径 Cylinder diameter
R8B R8BD3	2200r/min	0~7mm	14mm	DP×17	65mm



(红杉电控)

(红杉电控)



R8B-A

R8BLD3/8BLD3-A

筒式综合送料大梭单直驱电脑高车

Direct Drive Cylinder Bed Walking Foot Lockstitch Sewing Machine (Bobbin Diameter: 22mm)

R8918 竖筒型综合送料高柱车

Post Bed Walking Foot Lockstitch Sewing Machine

产品介绍

PRODUCT INTRODUCTION

- 本机是专为ABS拉杆箱制造设计的立柱式高车，结构坚实，造型新颖。
- 采用滑杆挑线，构成双线锁式线迹，上下轴用同步齿形带传动。
- 压脚、送布牙、机针同步送料，杠杆式针距调节机构。
- 高压脚行程，高压脚提升空间，大针距设计。
- 适合于拉杆箱、汽车座椅、家具、马靴的缝绉。
- Post bed sewing machine specially designed for ABS luggage suitcase manufacturing, solid mechanism and novel shape.
- The sliding rod is used to pick the thread to form a double-thread lock stitch, and the top and bottom shafts are driven by synchronous toothed belts.
- Compound feeding composed of pressure foot, feeding teeth, and machine needle, with a lever type needle distance adjustment mechanism.
- Higher presser foot lifting height.
- Suitable for sewing thick material products such as ABS plastic suitcase, car seats, furniture, and riding boots, etc.

技术参考

TECHNICAL PARAMETERS

型号 Model	转速 Max. sewing speed	针轨长度 Stitch length	压脚高度 Presser foot lift height	机针型号 Needle model
R8918	1600r/min	0-12mm	16mm	DD×1

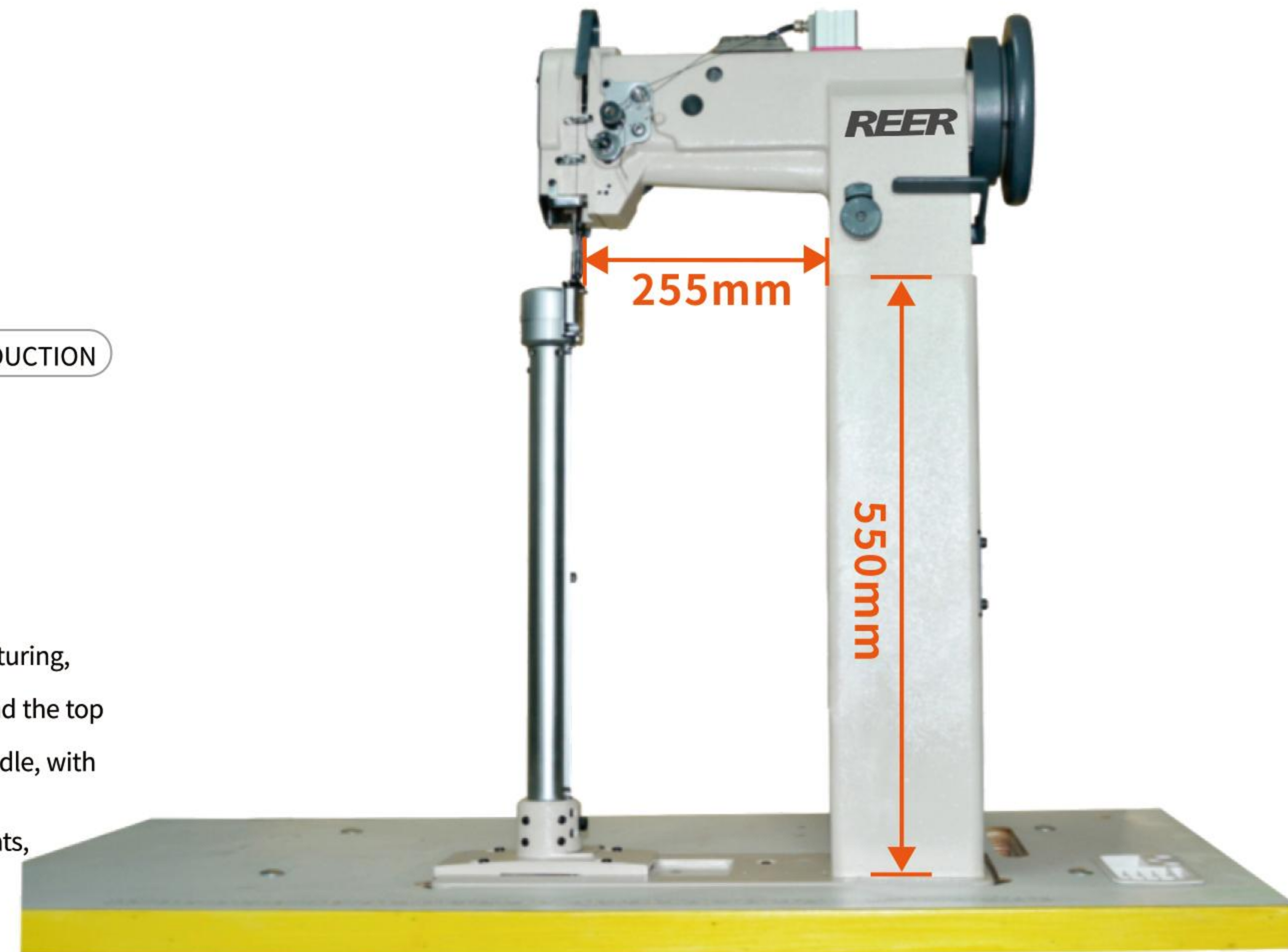

R8918-15/R8918-18
竖筒型综合送料高柱车
Post Bed Walking Foot Lockstitch Sewing Machine

R8365S 竖筒型综合送料高柱车

Post Bed Walking Foot Lockstitch Sewing Machine

产品介绍

PRODUCT INTRODUCTION

- 采用三同步综合送料，缝制厚薄物品均匀美观。
- 竖长型的釜座设计(釜座高度443mm)。
- 特殊小角度的针板，送布牙设计，增加使用方便性。
- Compound feeding composed of pressure foot, feeding teeth, and machine needle, so the sewing effect is stable and beautiful.
- Post bed height is 443mm.
- Special small angle needle plate and feed dog design increase convenience of use.

技术参考

TECHNICAL PARAMETERS

型号 Model	最大转速 Max. Sewing Speed	针轨长度 Stitch length	压脚高度 Presser foot lift height	机针型号 Needle model
R8365 R8365-A	1600r/min	0-8mm	15mm	DP×17



柱高可选尺寸180/250/305/350mm
Post height optional size: 180/250/305/350mm



R8365S/R8365D3-A
竖筒型综合送料高柱车
Post Bed Walking Foot Lockstitch Sewing Machine

R8365R(360°)

360度水平旋转柱车

360 Degree Horizontal Rotary Post Bed Walking Foot Lockstitch Sewing Machine

产品介绍

PRODUCT INTRODUCTION

- 采用左右任意方向水平转动缝纫、满足特殊缝纫需求。
- 大功率电子下挂马达，缝制线迹美观。
- 适用于小件皮具，筒型与曲状物品的缝纫。
- It adopts horizontal sewing in any direction of left and right to meet the needs of special sewing needs, and is suitable for the sewing of small leather goods, barrel and curved items.
- High-power servo motor, beautiful sewing stitches.
- Suitable for sewing small leather goods, cylindrical and curved items.

技术参考

TECHNICAL PARAMETERS

型号 Model	最大转速 Max. Sewing Speed	针轨长度 Stitch length	压脚高度 Presser foot lift height	机针型号 Needle model
R8365R R1341S	1600r/min	0~6mm	15mm	DP×17



产品简介

PRODUCT INTRODUCTION

- 采用摆臂前后180°转动，满足窄小空间物品缝纫，直驱大功率品牌电控，缝制有力稳顺，线迹美观。
- The swing arm rotates 180 degrees forward and backward for sewing, which is suitable for sewing items in small spaces. Direct drive and high-power brand servo motor ensures powerful, stable sewing and beautiful stitches.

R1341S(180°)

180度前后摆臂车

180 Degree Rotary Post Bed Walking Foot Lockstitch Sewing Machine



R5500DT/R5520DT

单双针自动剪线综合送料平缝机

One/Two Needle Automatic Thread Trimming Walking Foot Lockstitch Sewing Machine

产品介绍

PRODUCT INTRODUCTION

- 本机采用自动剪线、气动倒缝、气动抬压脚，气动松线，可手动调节压脚交互量，一键启动，大旋梭，自动润滑，LED照明，大功率伺服电机，噪音低、振动小、节能高效。
- 外形设计新颖流畅，压脚提升和倒缝采用气动控制，极大地减轻操作者的劳动强度。
- 双针机型的针距有多种规格供选择。
- 适用于用于汽车脚垫、安全带、汽车内饰、沙发、箱包、帐篷等厚料的缝制。
- This machine adopts automatic thread trimming, pneumatic presser foot lifting and reverse stitching, and pneumatic thread loosening. It can manually adjust the presser foot lift height, one-button start, large capacity shuttle hook&bobbin, automatic oil supply, LED lighting, high-power servo motor, and low consumption. High performance, ultra-quiet, less vibration, energy saving and environmental protection.
- Novel and smooth appearance design.
- The two-needle machines are available in customized needle gap sizes.
- Suitable for sewing thick materials such as plastic suitcases, handbags, hats, shoes, tents, sofas, car mates/seats, heavy leather or canvas materials and more.



技术参考

TECHNICAL PARAMETERS

型号 Model	最大转速 Max. Sewing Speed	针轨长度 Stitch length	压脚高度 Presser foot lift height	机针型号 Needle model
R5500DT R5520DT	2200r/min	0~11mm	16mm	DP×17

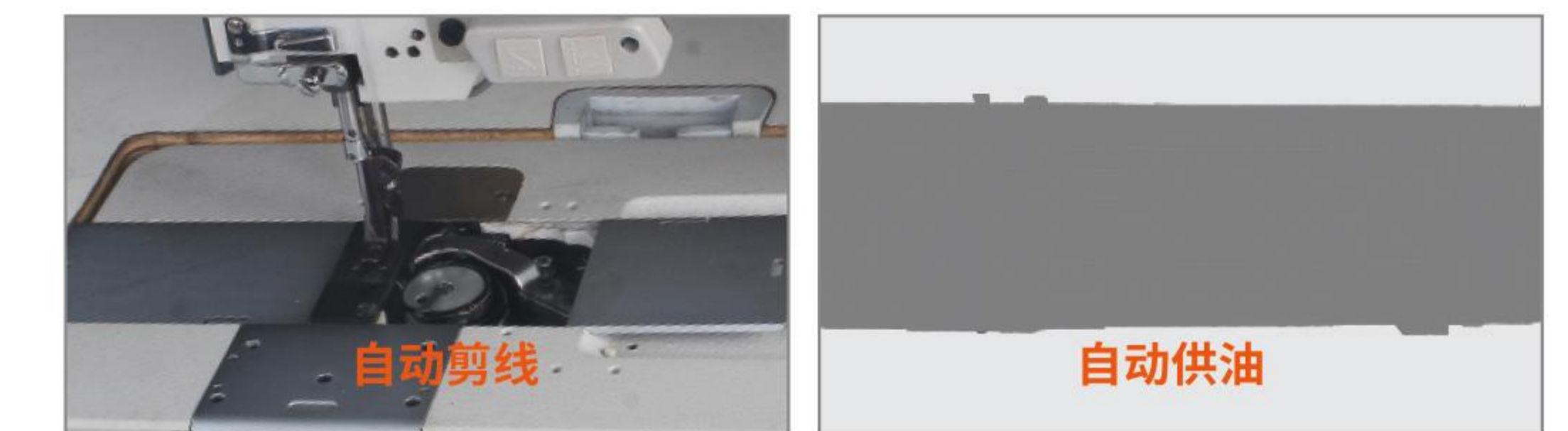

R4400D3-4420

单双针综合送料平缝机

One/Two Needle Compound Feed Walking Foot Lockstitch Sewing Machine

R6600-25/R6620-25

单双针综合送料平缝机

One/Two Needle Compound Feed Walking Foot Lockstitch Sewing Machine

产品介绍

PRODUCT INTRODUCTION

- 此机为加长版综合送料DU车, 缝制大尺寸物料更优秀, 加上大功率节能电机, 气动倒缝和气动抬压脚、高效节能。
- 双针机型的针距有多种规格供选择。
- 适用于用于汽车脚垫、安全带、汽车内饰、沙发、箱包、帐篷等厚料的缝制。
- This machine is an extended version of the compound feeding DU sewing machine, which is better for sewing large-size materials. It is equipped with a high-power energy-saving servo motor, pneumatic reverse stitching and pneumatic presser foot lift, which is energy-saving and efficient.
- The two-needle machines are available in customized needle gap sizes.
- Suitable for sewing thick materials such as plastic suitcases, handbags, hats, shoes, tents, sofas, car mats/seats, heavy leather or canvas materials and more.

技术参考

TECHNICAL PARAMETERS

型号 Model	最大转速 Max. Sewing Speed	针轨长度 Stitch length	压脚高度 Presser foot lift height	机针型号 Needle model
R6620-25 R4420H-7	2200r/min	0~12mm	16mm	DP×17

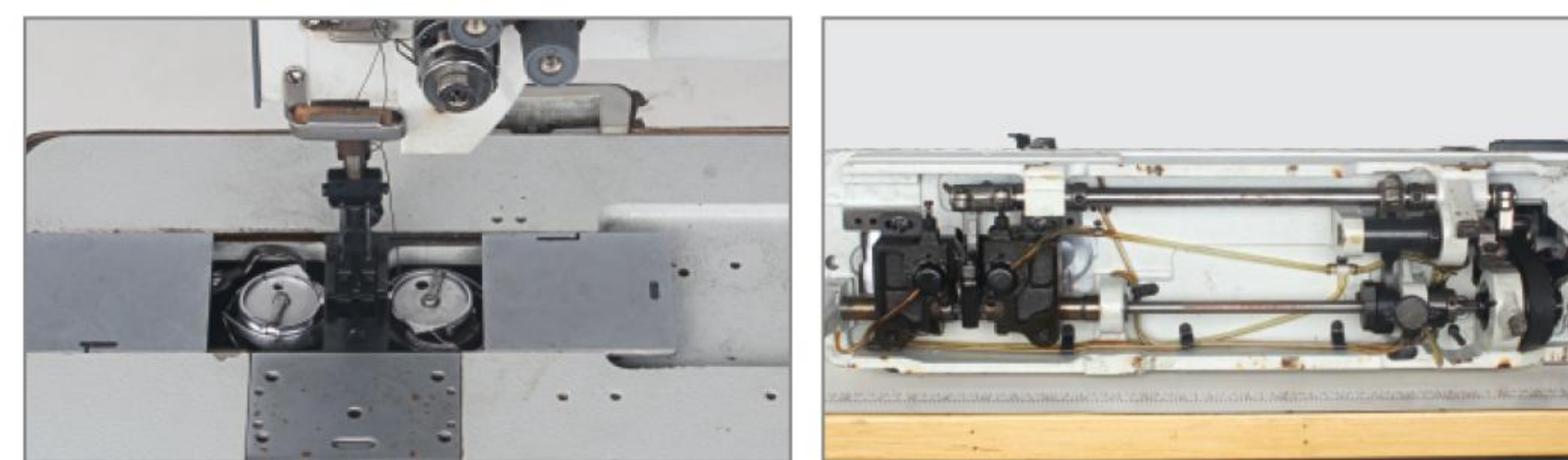
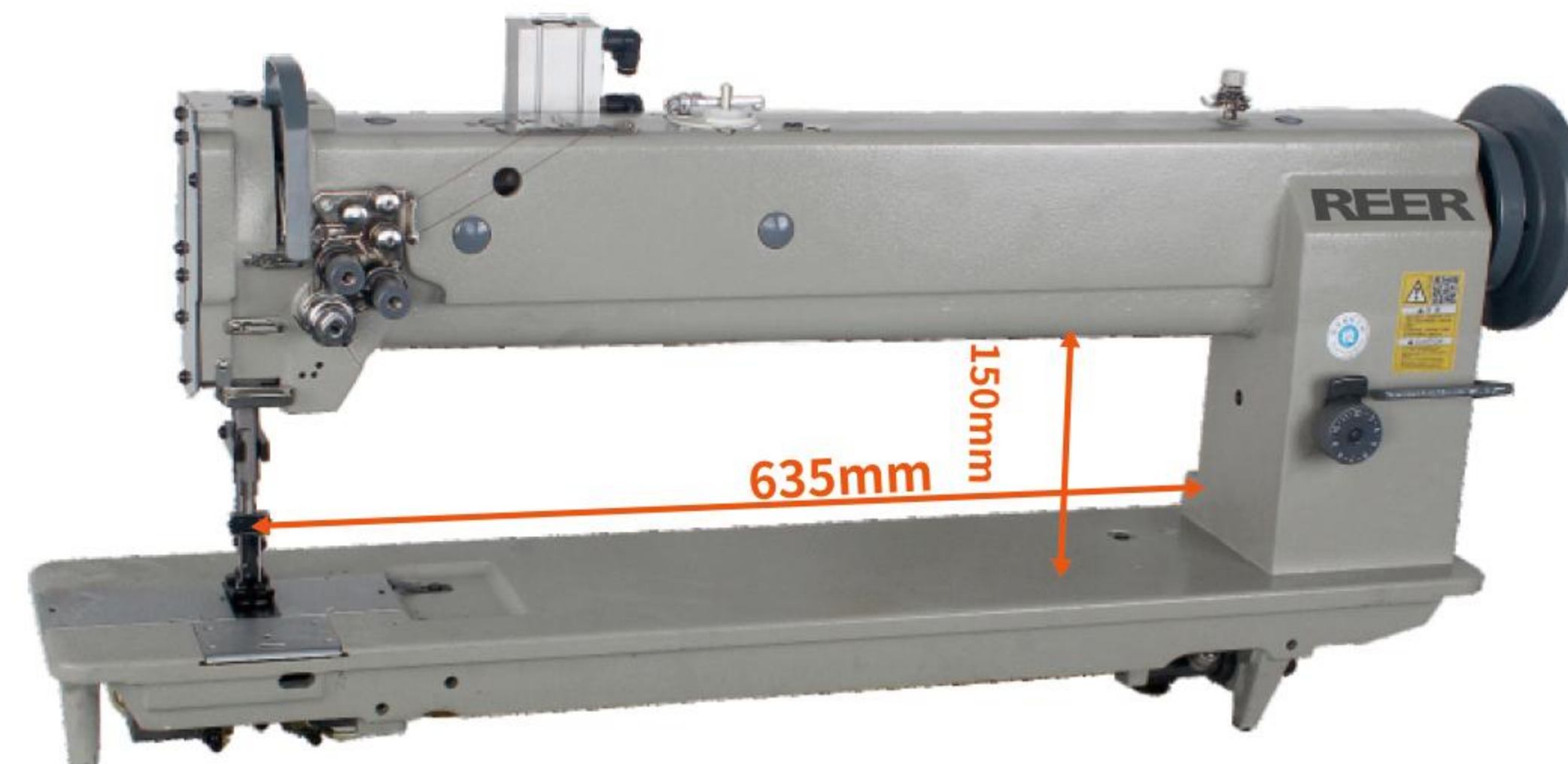

产品介绍

PRODUCT INTRODUCTION

- 采用大型立式旋梭勾线滑杆挑线。
- 同步齿形带传送柱塞式油泵润滑系统。
- 传动轻滑噪音小耐用度高。
- It adopts a large vertical rotary hook to take up the thread and a sliding rod to take up the thread.
- Synchronized toothed belt transmission plunger oil pump lubrication system.
- The transmission is light and smooth, with low noise and high durability.



R4420H-7

竖长型双针综合送料矮柱车

Post Bed Two Needle Compound Feed Walking Foot Lockstitch Sewing Machine

R6600-40/R6620-40

加长型单双针综合送料平缝机

Long Arm One/Two Needle Compound Feed Walking Foot Lockstitch Sewing Machine

产品介绍

PRODUCT INTRODUCTION

- 此机为加长版综合送料DU车, 缝制大尺寸物料更优秀, 加上大功率节能电机, 气动倒缝和气动抬压脚、高效节能。
- 双针机型的针距有多种规格供选择。
- 适用于用于汽车脚垫、安全带、汽车内饰、沙发、箱包、帐篷等厚料的缝制。
- This machine is an extended version of the compound feeding DU sewing machine, which is better for sewing large-size materials. It is equipped with a high-power energy-saving servo motor, pneumatic reverse stitching and pneumatic presser foot lift, which is energy-saving and efficient.
- The two-needle machines are available in customized needle gap sizes.
- Suitable for sewing thick materials such as plastic suitcases, handbags, hats, shoes, tents, sofas, car mats/seats, heavy leather or canvas materials and more.

技术参考

TECHNICAL PARAMETERS

型号 Model	最大转速 Max. Sewing Speed	针轨长度 Stitch length	压脚高度 Presser foot lift height	机针型号 Needle model
R6620-40	2000r/min	0~12mm	16mm	DP×17



R243

综合送料摆梭粗线平缝机

Flat Bed Compound Feed Walking Foot Lockstitch Sewing Machine

产品介绍

PRODUCT INTRODUCTION

- 本机是厚料机系列中的大力士, 它采用三同步综合送料系统: 机针、送布牙和压脚交叉升降机构, 保证在额定范围内的任何长度针距下、缝制滑性、粘性缝料及特长制品时上下层不位移、使缝制品整齐、线迹美观。
- 本机压脚提升量可达25毫米。
- 差动压脚交替量达到10mm。
- This model is suitable for sewing ultra-thick material products. It adopts a three-synchronous comprehensive feeding system: needle, feed dog and presser foot cross-lifting mechanism to ensure that the upper and lower layers do not shift when sewing slippery, sticky sewing materials and special-length products at any stitch length within the rated range. Sewn products are neat and the stitches are beautiful.
- Max sewing stitch 12mm.
- Max sewing thickness 25mm.

技术参考

TECHNICAL PARAMETERS

型号 Model	最大转速 Max. Sewing Speed	针轨长度 Stitch length	压脚高度 Presser foot lift height	机针型号 Needle model
R243	800r/min	0~12mm	25mm	Dy×3

R441 筒式摆梭综合送料粗线车 Cylinder Bed Compound Feed Walking Foot Lockstitch Sewing Machine

产品介绍

PRODUCT INTRODUCTION

- 本机是极厚料机系列中的大力士,采用综合送料方式&圆筒形缝台。
- 送料力量强劲稳定,能轻易车缝多层厚重物料,线迹精准美观。
- 采用高品质特种摆梭,梭芯线量大,缝制效率高。
- 梭芯绕线装置位于机头上部,压脚提升置可达25mm。
- 可适用于缝制手提袋的手把,棒球手套、运动器材、安全袋、沙发帐篷、汽车脚垫、箱包等厚料物品。
- This machine is suitable for sewing ultra-thick material products and adopts a compound feeding walking foot system.
- The feeding force is strong and stable, and it can easily sew multiple layers of thick materials with precise and beautiful stitches.
- High-quality shuttle hook, large-capacity bobbin, high sewing efficiency.
- Max sewing stitch 12mm, max sewing thickness 25mm.
- Suitable for sewing saddles, handbag handles, baseball gloves, sports equipment, seat belts, sofas, tents, car mats, bags and other thick materials.



技术参考

TECHNICAL PARAMETERS

型号 Model	转速 Max. sewing speed	针轨长度 Stitch length	压脚高度 Presser foot lift height	机针型号 Needle model	筒径 Cylinder diameter
R441	800r/min	0-12mm	25mm	DY×3	85mm



产品介绍

PRODUCT INTRODUCTION

- 441F-37是专业为箱包盖缝绉设计的大摆梭粗线车,可分离升降机头设计,缝绉更轻松便捷、省力高效。
- 441HX采用小直径筒形缝台,小摆梭横向缝绉有力,线迹紧实美观,满足横缝方向线迹物品的特殊缝绉。
- JL-441D-37 is a large bobbin thick thread sewing machine specially designed for sewing luggage covers. It can separate or lift the machine head, making sewing easier, more convenient, labor-saving and efficient.
- 441HX adopts a small-diameter cylindrical sewing table. The small shuttle hook is powerful for horizontal sewing, and the stitches are tight and beautiful, which can meet the special needs of sewing items with stitches in the horizontal direction.



R441F-37/R44HX-24 单针综合送料摆梭平缝机 Single Needle Cylinder Bed Compound Feed Walking Foot Lockstitch Thick Thread Sewing Machine

R8420DT/R8720DT 双针针送自动剪线平缝机 Flat Bed Automatic Thread Trimming Compound Feed Walking Foot Lockstitch Sewing Machine

产品介绍

PRODUCT INTRODUCTION

- 外观新颖,直驱伺服马达,低噪音、少振动,节能环保。
- 采用优良的送布机构,在低张力的状态下能防止高速时的跳动,大大提高了生产效率。
- 由于机针和送牙布同步送料,能防止缝料滑移。
- 适用于高质量的双针明缝、角缝自动剪线,自动倒缝,自动扫线,自动抬压脚、自动线芯、便捷高效。
- 适合车缝皮具类,帐篷,服装类车缝作业。
- Patent design, beautiful and novel. Direct drive servo motor: low energy consumption, low noise, more energy-saving and eco-friendly.
- Adopting an excellent feeding structure, it can prevent the beating at high speed under low tension, which greatly improves production efficiency.
- The machine needle and feed dog feed simultaneously, which can prevent the sewing material from slipping.
- Suitable for high-quality two-needle top-stitching, corner stitching. This machine includes automatic thread trimming, automatic presser foot lifting and reverse stitching, automatic thread sweeping, and automatic winding thread, which is convenient and efficient.
- Suitable for sewing leather goods, tents, jeans, clothing and other products.

技术参考

TECHNICAL PARAMETERS

型号 Model	最大转速 Max. Sewing Speed	针轨长度 Stitch length	压脚高度 Presser foot lift height	机针型号 Needle model
R8720DT R842	3000r/min	0-5mm	7mm	DP×5

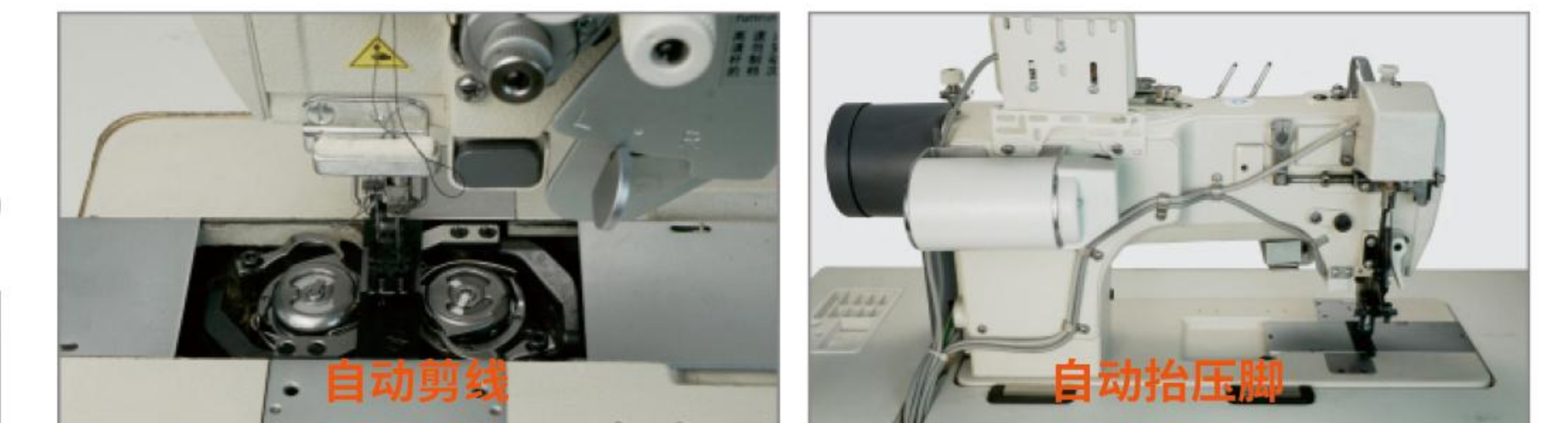

R842/R872D3 双针针送平缝机 Two Needles Flat Bed Compound Feed Walking Foot Lockstitch Sewing Machine

R335PF

筒式水平送料小嘴包边车

Cylinder Bed Compound Feed Walking Foot Lockstitch Sewing Machine (Cylinder Diameter 46mm)

产品介绍

PRODUCT INTRODUCTION

- 采用大釜,梭芯的底线增加40%,可提高缝制效率。
 - 圆筒直径46mm,车缝较大物品或筒状物品之时,转动灵活,缝目大小调节容易。
 - 在缝纫人员视线内的嵌装于机头的绕线器。
 - 高低速针距变化误差率小。
 - 适用于皮革、鞋帽、手袋、潜水料等包边作业。
- Using a large rotary hook, the bottom thread of the bobbin is increased by 40%, which can improve sewing efficiency.
 - The cylinder diameter is 46mm, and it can rotate flexibly when sewing larger items or tubular items.
 - The bobbin winder is on top of the machine.
 - The error in needle gap changes at high and low speeds is small.
 - Suitable for binding sewing of leather goods, shoes & hats, handbags, diving materials, etc.

技术参考

TECHNICAL PARAMETERS

型号 Model	转速 Max. sewing speed	针轨长度 Stitch length	压脚高度 Presser foot lift height	机针型号 Needle model	筒径 Cylinder diameter
R335 R335PF	2000r/min	0~8mm	15mm	DP×17	46mm

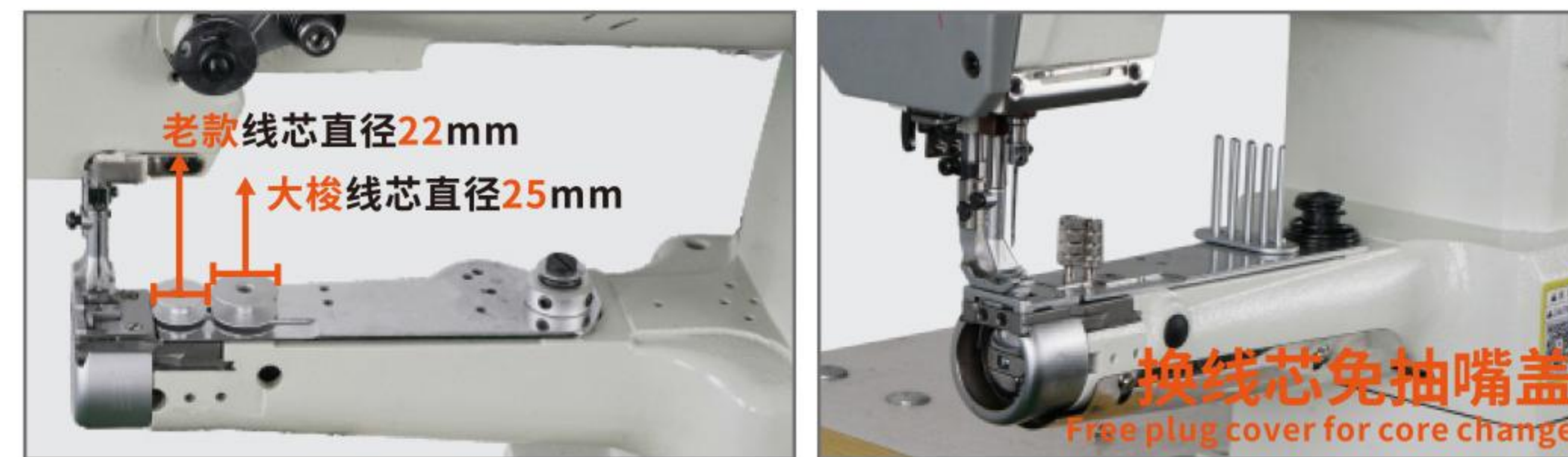

RG335PF/R2628D

筒式水平送料小嘴包边车

Cylinder Bed Compound Feed Walking Foot Lockstitch Sewing Machine (Cylinder Diameter 46mm)



(琦星电控)

R0303D

自动剪线电脑同步车

Direct Drive Compound Feed Automatic Thread Trimming Walking Foot Lockstitch Sewing Machine

产品介绍

PRODUCT INTRODUCTION

- 采用连杆式上下送料机构和压脚交替提升机构,保证送料顺畅。
 - 采用自动润滑装置,最高速度可达2500转/分钟。
 - 采用最新的缝制效果,实现了低张力缝制的优点。
 - 压脚提升轴采用密封式自动润滑。
 - 具有自动剪线,自动倒缝,电子夹线等功能,增加工作效率,减少人工成本。
- Adopting a connecting rod type upper and lower feeding structure and a presser foot alternating lifting structure to ensure smooth feeding.
 - Automatic oil supply, maximum speed up to 2500 rpm.
 - Using the latest sewing effects, the advantages of low-tension sewing are realized.
 - The presser foot lifting shaft adopts sealed automatic lubrication.
 - With automatic thread cutting, automatic reverse stitching, automatic clamping and other functions, increase work efficiency and reduce labor costs.

技术参考

TECHNICAL PARAMETERS

型号 Model	最大转速 Max. Sewing Speed	针轨长度 Stitch length	压脚高度 Presser foot lift height	机针型号 Needle model
R0303D	2500r/min	0~10mm	13mm	DP×17



谷立电控

R0303D2/R0303D1-Q

自动剪线电脑同步车

Direct Drive Compound Feed Automatic Thread Trimming Walking Foot Lockstitch Sewing Machine



R0303DH 自动剪线电脑同步车

Direct Drive Compound Feed Automatic Thread Trimming Walking Foot Lockstitch Sewing Machine

产品介绍 PRODUCT INTRODUCTION

- 采用连杆式上下送料机构和压脚交替提升机构, 保证送料顺畅。
- 采用自动润滑装置, 最高速度可达2500转/分钟。
- 采用最新的缝制效果, 实现了低张力缝制的优点。
- 压脚提升轴采用密封式自动润滑。
- 具有自动剪线, 自动倒缝, 电子夹线等功能, 增加工作效率, 减少人工成本。
- Adopting a connecting rod type upper and lower feeding structure and a presser foot alternating lifting structure to ensure smooth feeding.
- Automatic oil supply, maximum speed up to 2500 rpm.
- Using the latest sewing effects, the advantages of low-tension sewing are realized.
- The presser foot lifting shaft adopts sealed automatic lubrication.
- With automatic thread cutting, automatic reverse stitching, automatic clamping and other functions, increase work efficiency and reduce labor costs.

技术参考 TECHNICAL PARAMETERS

型号 Model	最大转速 Max. Sewing Speed	针轨长度 Stitch length	压脚高度 Presser foot lift height	机针型号 Needle model
R0303D	2500r/min	0~10mm	13mm	DP×17



R0303DH-RD/R0306D2-Q 自动剪线&小嘴电脑同步车

Direct Drive Automatic Thread Trimming & Small Cylinder Bed Lockstitch Sewing Machine

R0303DX-Q 自动剪线电脑同步车

Direct Drive Automatic Thread Trimming & Triple Bobbin Walking Foot Lockstitch Sewing Machine

产品介绍 PRODUCT INTRODUCTION

- 专利外观、美观新颖, 采用LED大显示屏设计。
- 采用连杆式上下送料机构和压脚交替提升机构, 保证送料顺畅。
- 采用自动润滑装置, 最高速度可达2500转/分钟。
- 采用最新的缝制效果, 实现了低张力缝制的优点。
- 压脚提升轴采用密封式自动润滑。
- 具有自动剪线, 自动倒缝, 电子夹线等功能, 增加工作效率, 减少人工成本。
- R0303DLX采用三倍大旋梭设计, 更高效。

- Patented appearance, beautiful and novel, using LED display screen design.
- Adopting a connecting rod type upper and lower feeding structure and a presser foot alternating lifting structure to ensure smooth feeding.
- Automatic oil supply, maximum speed up to 2500 rpm.
- Using the latest sewing effects, the advantages of low-tension sewing are realized.
- The presser foot lifting shaft adopts sealed automatic lubrication.
- With automatic thread cutting, automatic reverse stitching, automatic clamping and other functions, increase work efficiency and reduce labor costs.
- R0303DLX adopts a triple-capacity shuttle hook&bobbin design, which is more efficient.

技术参考 TECHNICAL PARAMETERS

型号 Model	最大转速 Max. Sewing Speed	针轨长度 Stitch length	压脚高度 Presser foot lift height	机针型号 Needle model
R0303D R8700D	2500r/min 3000r/min	0~10mm	13mm	DP×17



R8700D/R8900D 自动剪线大梭&小梭电脑平车

Fled Bed Direct Drive Automatic Thread Trimming Lockstitch Sewing Machine



RD01 纯电动款包边热切机

Electric Drive Edge Tape Hot Heat Cutting Machine

产品介绍

PRODUCT INTRODUCTION

- 专利号(The patent number) :
ZL 2022 2 3552440.7
ZL 2022 2 2088347.9
- 纯电动款热切机只需插电、无需接气。
- 专利双滚轮送料结构、送料稳定。
- 专利热切组件、热切刀耐用不易变形。
- 快速安装、送料无噪音。
- 包边热切织带、自动送织带。
- Electrically driven hot heat cutting machines only need to be plugged in, no need to connect to an air compressor.
- Patented double roller feeding structure, stable feeding.
- Patented hot-heating component, the hot-heating knife is durable and not easily deformed.
- Operation-friendly and noiseless feeding.
- Binding products can directly cut the material and automatically feeding.

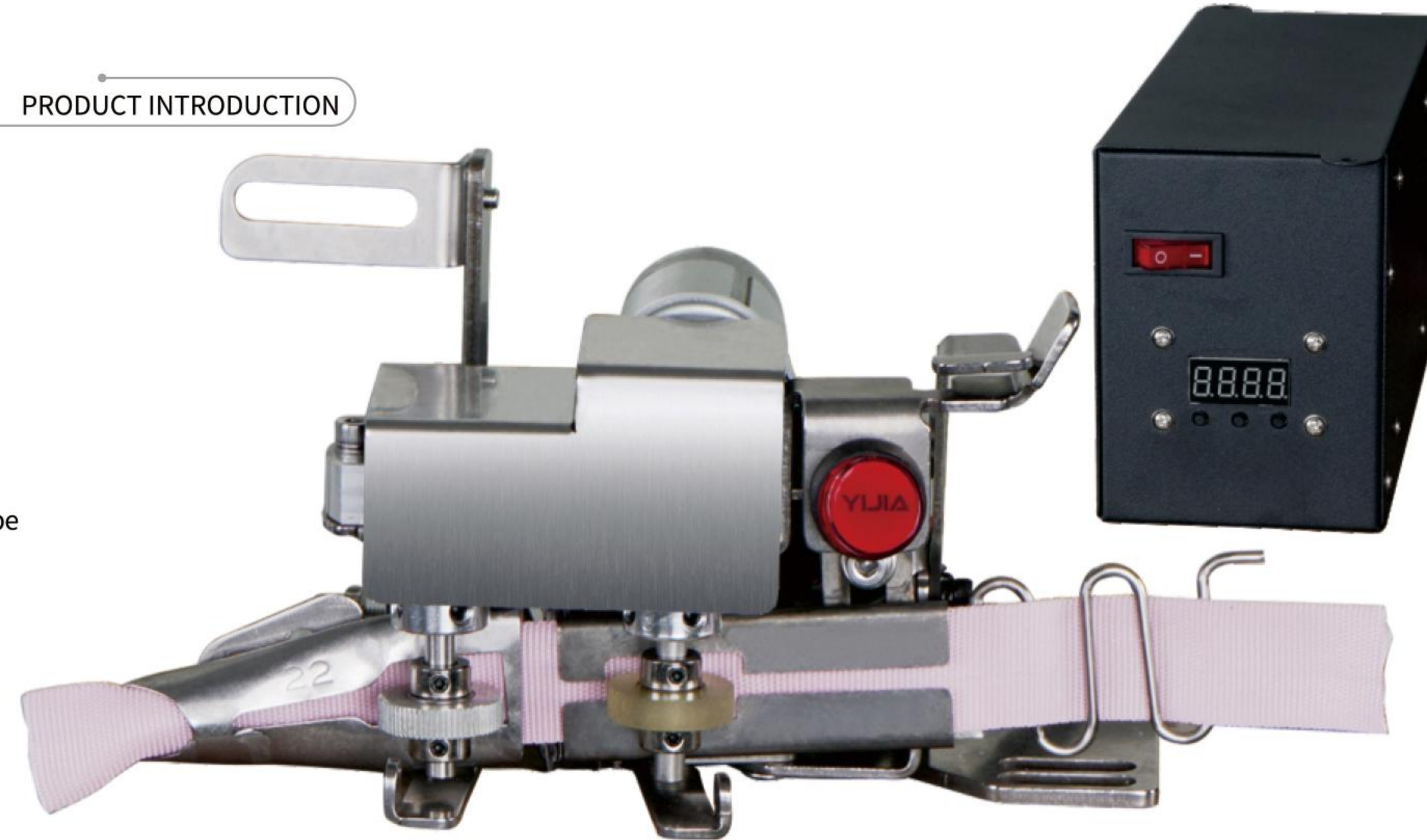

应用机型广泛

Wide range of application models



RQ301 气动款包边热切机

Pneumatic Drive Edge Tape Hot Heat Cutting Machine

产品介绍

PRODUCT INTRODUCTION

- 专利号(The patent number) :
ZL 2022 2 0650373.3
ZL 2022 2 1257349.X
ZL 2022 2 2321234.9
ZL 2022 2 2088347.9
- 气动款热切机需要通气通电。
- 专利先顶紧织带料, 轻松切断, 无需再用手拉。
- 专利电磁阀组件, 单独电磁阀辅助吹气送料。
- 专利热切组件, 热切刀耐用不易变形。
- 包边热切织带、自动送织带, 送料顺畅、安装简单。
- Pneumatic drive model need to be connected to the air compressor to power on.
- Patented method of tightening the webbing first to make the cut smooth.
- Paented solenoid valve assembly, separate solenoid valve for feeding materials to assist blowing.
- Patented hot-heating component, the hot-heating knife is durable and not easily deformed. Operation-friendly and noiseless feeding.
- Binding products can directly cut the material and automatically feeding.

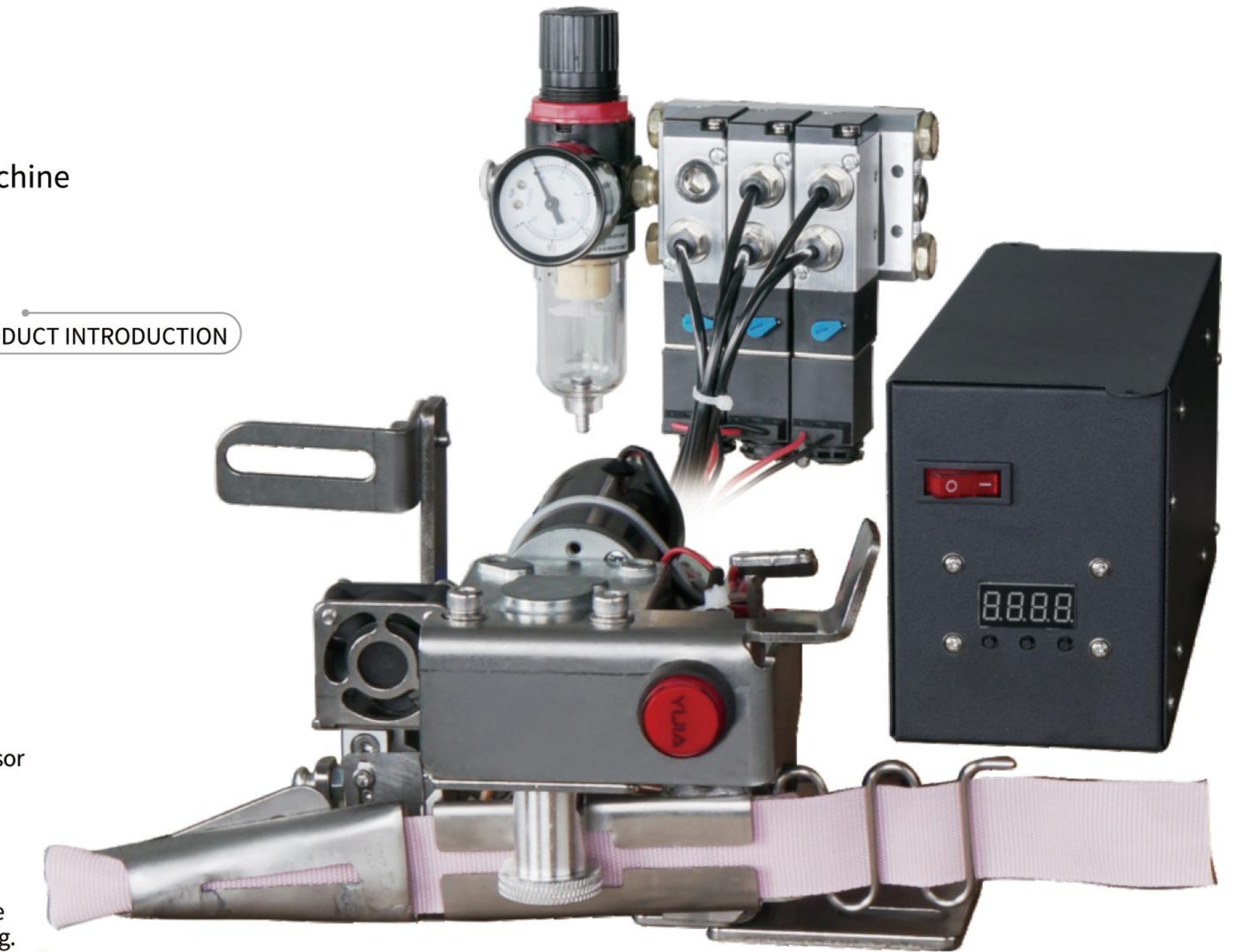

应用机型广泛

Wide range of application models

